

# PEREGRINE LUNAR LANDER

## PAYLOAD USER'S GUIDE



Publicly available document, please contact Astrobotic Technology for more details.  
June 2020 // Version 4.0



# TABLE OF CONTENTS

|   |           |
|---|-----------|
| <b>ABOUT US</b> .....                     | <b>3</b>  |
| What We Do .....                          | 4         |
| Service Overview .....                    | 5         |
| Payload Experience .....                  | 6         |
| Astrobotic Lunar Services.....            | 7         |
| Lunar Orbit Delivery Locations .....      | 8         |
| Lunar Surface Delivery Locations .....    | 9         |
| <b>PEREGRINE</b> .....                    | <b>10</b> |
| Peregrine Bus System .....                | 11        |
| <i>Mid-Latitude Configuration</i> .....   | 12        |
| <i>Polar Configuration</i> .....          | 13        |
| Structure .....                           | 14        |
| Propulsion .....                          | 15        |
| Guidance, Navigation, and Control .....   | 16        |
| Power .....                               | 17        |
| Avionics.....                             | 18        |
| Communications .....                      | 19        |
| Thermal Control .....                     | 20        |
| <b>INTERFACES</b> .....                   | <b>21</b> |
| Mechanical Environment.....               | 22        |
| Thermal Environment .....                 | 24        |
| Pressure and Humidity Environment.....    | 26        |
| <i>Pressure Environment</i> .....         | 26        |
| <i>Humidity Environment</i> .....         | 26        |
| Particle and Containment Environment..... | 27        |
| Radiation Environment .....               | 28        |
| Electromagnetic Environment .....         | 29        |
| Payload Types .....                       | 30        |
| Payload Mounting Accommodations.....      | 31        |
| Payload Mounting Decks .....              | 32        |
| Adapter Plates .....                      | 33        |
| Electrical Interfaces.....                | 34        |
| Release Mechanisms .....                  | 35        |
| Data Interfaces.....                      | 36        |
| Ground Segment.....                       | 37        |
| <b>MISSION OPERATIONS</b> .....           | <b>38</b> |
| Landing Site .....                        | 39        |
| Mission Profile .....                     | 40        |
| Trajectory.....                           | 41        |
| Descent Profile.....                      | 42        |
| Power Services.....                       | 43        |
| Data Services.....                        | 44        |
| Egress Procedures .....                   | 45        |
| <b>PAYLOAD INTEGRATION</b> .....          | <b>47</b> |
| Mission Timeline .....                    | 48        |
| Integration .....                         | 49        |
| <b>GLOSSARY</b> .....                     | <b>50</b> |
| Glossary of Units .....                   | 51        |
| Glossary of Terms .....                   | 52        |
| Glossary of Documentation .....           | 53        |
| Glossary of Milestones .....              | 54        |
| <b>CONTACT US</b> .....                   | <b>55</b> |
| Questionnaire.....                        | 56        |



# ABOUT US

# WHAT WE DO

Astrobotic is a lunar logistics company providing end-to-end delivery services for payloads to the Moon.

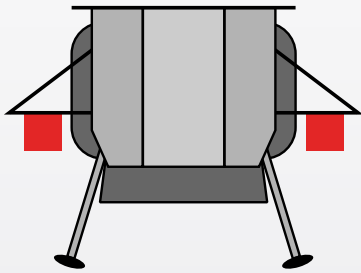

## PAYLOAD INTEGRATION

On each mission, Astrobotic works with payload customers to integrate their payloads onto a single Peregrine lunar lander.

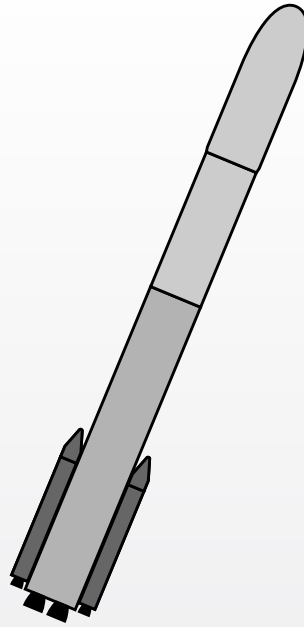

## LUNAR DELIVERY

Peregrine is launched on a commercially procured launch vehicle and safely delivers payloads to lunar orbit and the lunar surface.

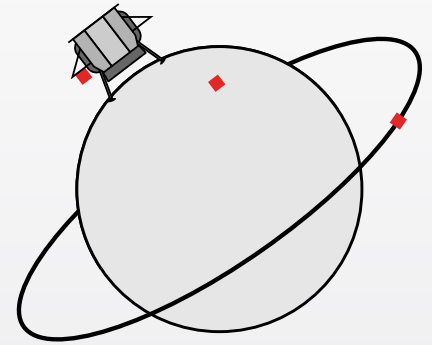

## PAYLOAD SERVICES

Peregrine provides power and data services to payloads during transit to the Moon and on the lunar surface.

Each payload customer receives comprehensive support from contract signature to end of mission. The Payload Customer Service Program equips the customer with the latest information on the mission and facilitates technical exchanges with Astrobotic engineers to ensure payload compatibility with the Peregrine lunar lander and overall mission success.

# SERVICE OVERVIEW

Companies, governments, universities, non-profits, and individuals can send payloads to the Moon at \$1.2M per kilogram of payload to the lunar surface.

Standard payload delivery options include lunar orbit and the lunar surface where payloads may remain attached to the lander, deploy from the lander for an independent mission, or hitch a ride on an Astrobotic lunar rover.

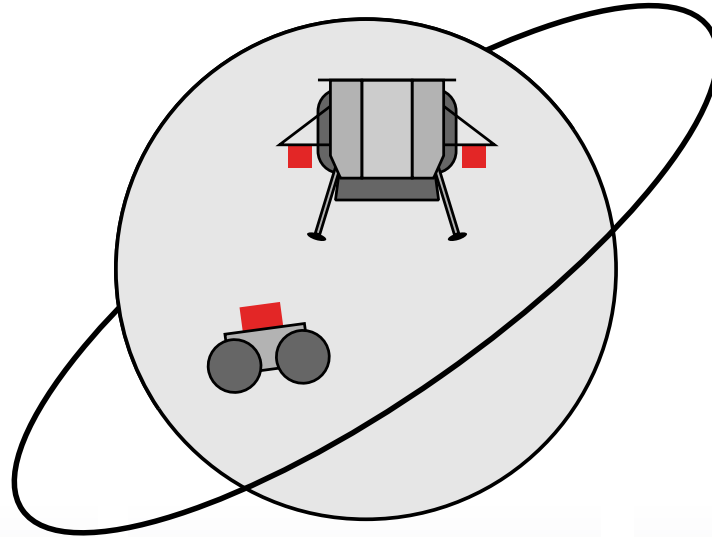

## LUNAR ORBIT

\$300,000/kg

## LUNAR SURFACE

\$1,200,000/kg

## DELIVERY ON ROVER

\$4,500,000/kg

For every kilogram of payload, Peregrine provides:



**1.0 Watt**  
POWER



**10 kbps**  
BANDWIDTH

Additional power and bandwidth are available for purchase upon request. Please contact Astrobotic to learn more.

*NOTE: Payloads less than 1 kg may be subject to integration fees. DHL MoonBox offers an affordable alternative to send small items to the Moon. Prices start at \$460.*

**[Check it out at astrobotic.com](https://astrobotic.com)**

# PAYLOAD EXPERIENCE



1

## SERVICES AGREEMENT

Following contract signature, the payload customer is connected with their payload manager to begin development of a schedule and an Interface Control Document.

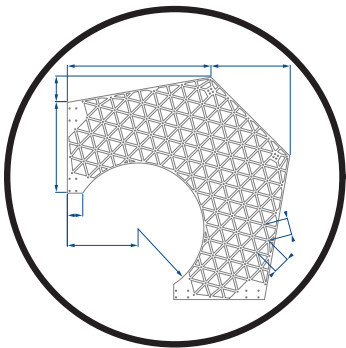

2

## TECHNICAL SUPPORT

Astrobotic supports the payload customer by hosting regular integration working group meetings, participating in payload design cycle reviews, and facilitating payload testing with simulated lander interfaces.



3

## INTEGRATION

The payload is sent to the Astrobotic integration facility. Astrobotic accepts the payload and integrates it onto Peregrine.



4

## MISSION

The integrated lander is launched and commences its mission. The Astrobotic Mission Control Center connects the customer to their payload during the flight to the Moon and on the lunar surface.

# ASTROBOTIC LUNAR SERVICES

Astrobotic is here to support the success of your payload mission. The standard payload interfaces and services are defined to enable nominal payload missions. This Payload User's Guide (PUG) provides an overview of these standard interfaces and services.

Astrobotic can accommodate payloads with needs outside of the standard interfaces and services at additional cost. Please contact Astrobotic to discuss any nonstandard requests such as custom interfaces, accommodation of large or unusual geometries, specific trajectory or landing site requirements, payload design consulting services, etc.

The Payload Customer Service Program is a standard service for all payload customers to provide the tools necessary to design a payload that successfully interfaces with Peregrine.

## The following features are included as part of the program:

### PAYLOAD CUSTOMER SERVICE PROGRAM

- 1 Availability for general and technical inquiries.
- 2 Bi-weekly technical exchanges with Astrobotic mission engineers.
- 3 Access to the Astrobotic library of payload design resources and standards.
- 4 Technical feedback through payload milestone design reviews.
- 5 Facilitation of lander-payload interface compatibility testing.

*NOTE: Access to materials within the Astrobotic library is not always restricted to signed customers. Please contact Astrobotic for more information on obtaining the latest version of any document referenced within the PUG.*

# LUNAR ORBIT DELIVERY LOCATIONS

Peregrine can deliver payloads to lunar orbit as well as the lunar surface. While the trajectory can change from mission to mission, Peregrine typically holds in three distinct Lunar Orbits (LO's), and two are available for payload deployment. The periapsis is consistent at 100 km while the apoapsis decreases through Lunar Orbit Insertion (LOI) maneuvers from 8700 km to a circular 100 km. The orbital inclination is typically determined by the surface landing site.

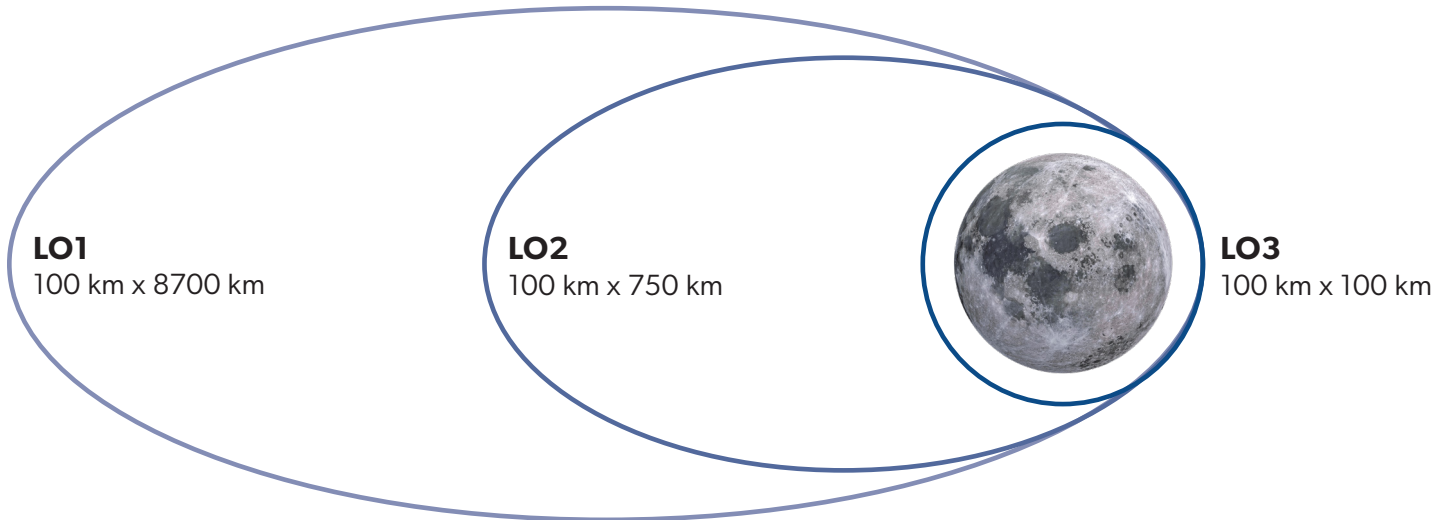

## LUNAR ORBIT 1 (LO1)

The initial lunar orbit, LO1 is a highly elliptical orbit. Peregrine nominally spends 12 hours in LO1. Nonstandard payload deployment may be available in this orbit upon request.

## LUNAR ORBIT 2 (LO2)

The next lunar orbit, LO2 is a stable elliptical orbit. The time Peregrine spends in LO2 depends on the launch date and subsequent trajectory as well as the orbital deployment schedule. All payload deployments are nominally planned for this orbit.

## LUNAR ORBIT 3 (LO3)

The final lunar orbit, LO3 is a circular orbit. Peregrine nominally spends 72 hours in LO3 for descent preparations. Payload deployment is not supported in this orbit.



# LUNAR SURFACE DELIVERY LOCATIONS

The Peregrine product line is capable of supporting payload missions to locations of interest from the lunar equator to the poles. Mission One will deliver payloads to a landing site near Lacus Mortis, 44°N, 25°E.

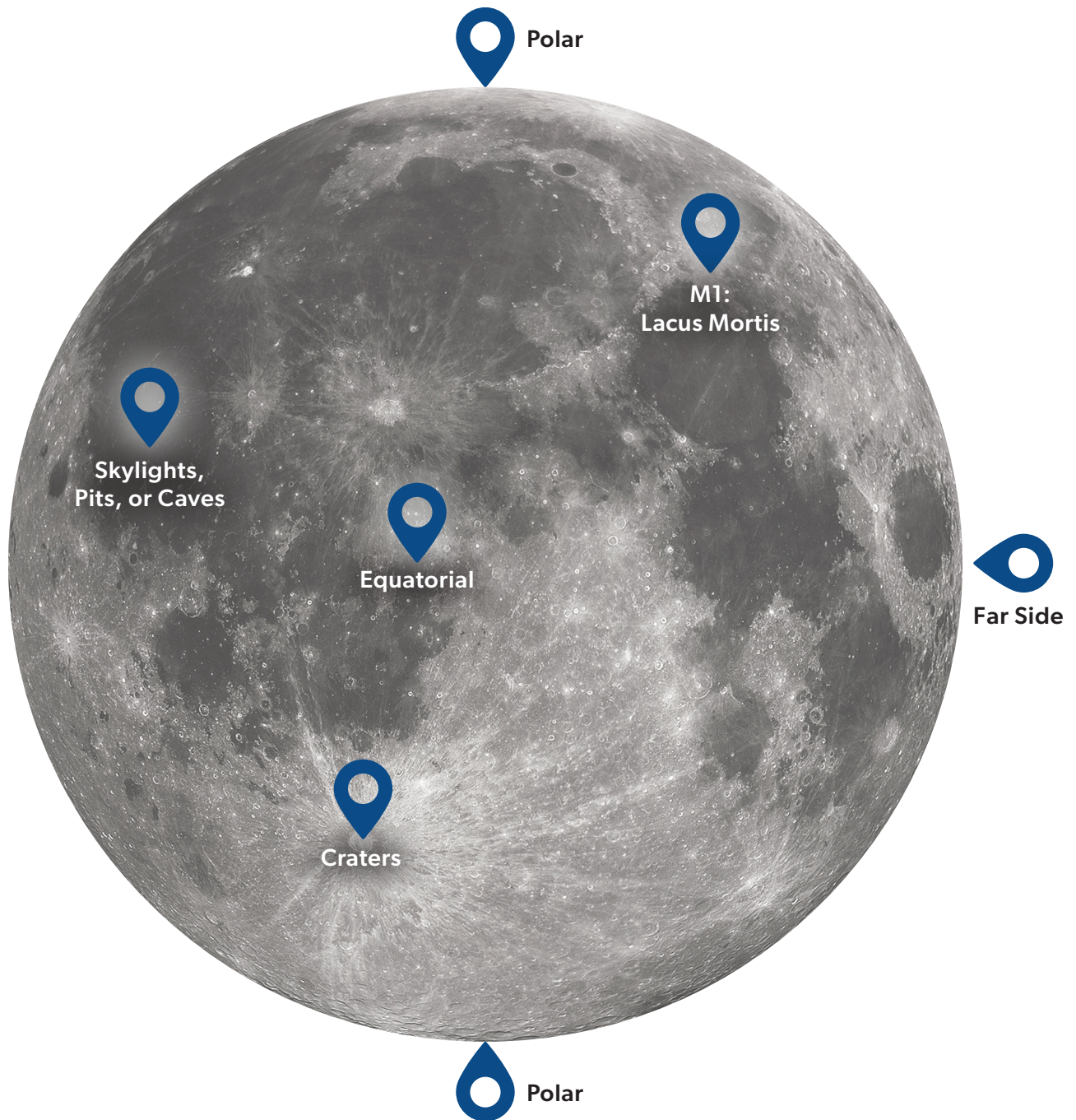

Starting with Mission Two, Peregrine will incorporate technology like Astrobotic's Optical Precision Autonomous Landing (OPAL) Sensor, a terrain relative navigation system to enable precision landing. This sensor, flown as a technology demonstration on Mission One, will enable polar landings and other missions requiring precision landing capabilities.

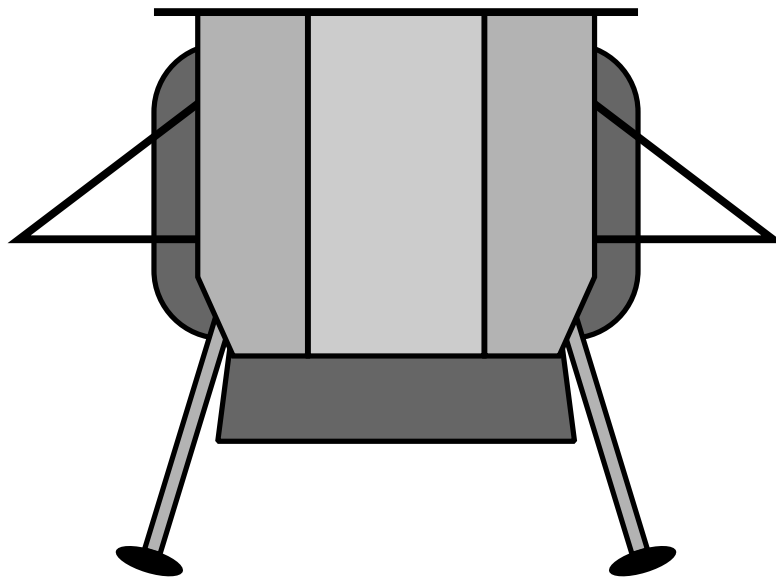

# PEREGRINE

# PEREGRINE BUS SYSTEM

A core set of systems, known as the bus, are maintained for every Peregrine configuration. The lander bus design enables safe payload delivery to lunar orbit and any latitude on the lunar surface. The bus can be arranged, augmented, and adapted to the various payload delivery locations. This flexibility allows Peregrine to accommodate a variety of payload types for science, exploration, marketing, resources, and commemoration. Other alterations to the lander bus, such as additional sensors for precision landing or a satellite communications relay for far-side operations, may be necessary depending on the specific mission.

**The Peregrine Bus System is comprised of the following systems.**

## PEREGRINE BUS SYSTEM

- 1 STRUCTURES**  
Provides mounting locations for payloads and lander systems.
- 2 PROPULSION**  
Maneuvers lander after separation from the launch vehicle.
- 3 GUIDANCE, NAVIGATION, AND CONTROL**  
Controls, orients, and flies the lander throughout the mission.
- 4 POWER**  
Generates, stores, and distributes power to payloads and lander systems.
- 5 AVIONICS**  
Performs all command and data handling for the lander.
- 6 COMMUNICATIONS**  
Provides communication services between ground stations and the lander.
- 7 THERMAL CONTROL**  
Regulates and controls thermal interfaces for lander systems.

The following pages highlight the mid-latitude and polar configurations of the Peregrine bus and explore each system in more detail. Additional configurations for lunar orbit, equatorial, far side, and many more delivery locations are possible. Contact Astrobotic for more details on specific configurations.



# MID-LATITUDE CONFIGURATION

Peregrine’s mid-latitude configuration is designed to land and operate at latitudes between 40° and 50° North or South. The lander features side radiators and a top mounted solar panel. This configuration will be flown on Astrobotic’s Mission One as a co-manifested payload aboard ULA’s Vulcan Centaur launch vehicle.



| MID-LATITUDE                            |           |
|---|-----------|
| Lunar Surface Payload Delivery Capacity | 100 kg    |
| Surface Operations Duration             | 192 hours |



# POLAR CONFIGURATION

Missions to the polar regions of the lunar surface feature side-mounted solar panels to produce sufficient power at higher latitudes and support payload needs. Lander avionics are mounted to a radiator at the top of the lander.

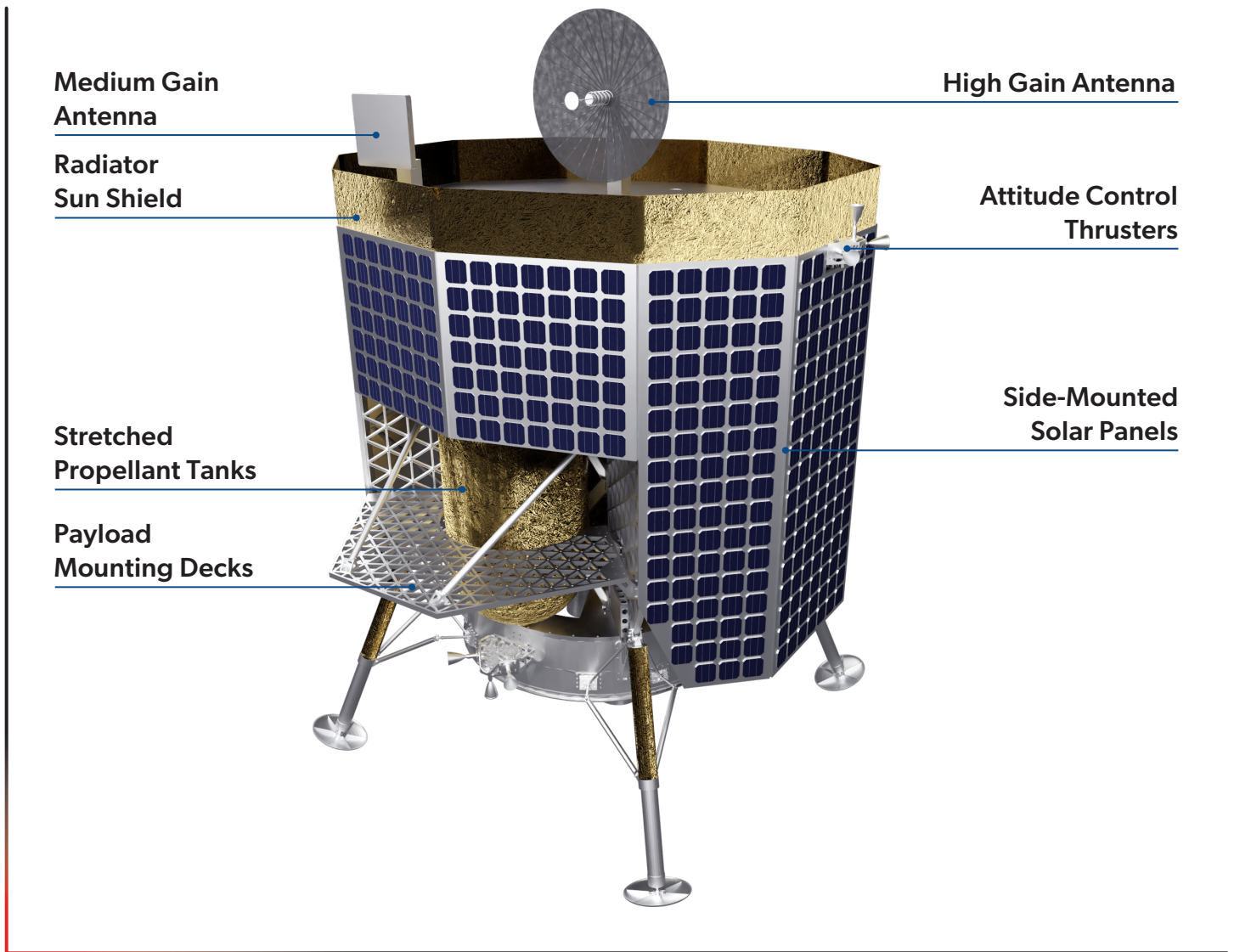

| POLAR                                   |            |
|---|------------|
| Lunar Surface Payload Delivery Capacity | 100 kg     |
| Surface Operations Duration             | 192+ hours |

*NOTE: Some polar landing sites have periods of continuous sunlight that last longer than a lunar day at midlatitude.*



# STRUCTURE

Peregrine's structure is strong, stiff, and lightweight for survivability during launch and landing. The bus structure is manufactured out of aluminum alloy and is comprised of three primary components, the launch vehicle adapter cone, isogrid shear panels, and two aluminum honeycomb enclosures. The standard physical mounting interface for the payloads is optimized for the specific mission profile. For missions to the lunar surface, four landing legs, designed to absorb shock and stabilize the craft on touchdown, are fastened to the bus structure.

## LAUNCH VEHICLE ADAPTER CONE

The launch vehicle adapter cone houses the main engines. Additionally, it serves as the adapter to the launch vehicle where a releasable clamp band mates Peregrine to the launch vehicle and enables separation.

## ISOGRID SHEAR PANELS

The aluminum isogrid shear panels support the secondary elements of the lander such as fuel tanks, payload mounting decks, and the solar panel. An internal truss structure ties the four shear panels together and serves as a central column for the structure.

## ENCLOSURES

The aluminum honeycomb enclosures provide mounting surfaces and protection for lander avionics. In some configurations these enclosures are also the primary radiators for the lander's thermal system. In other configurations they are converted to mounting surfaces for solar panels.

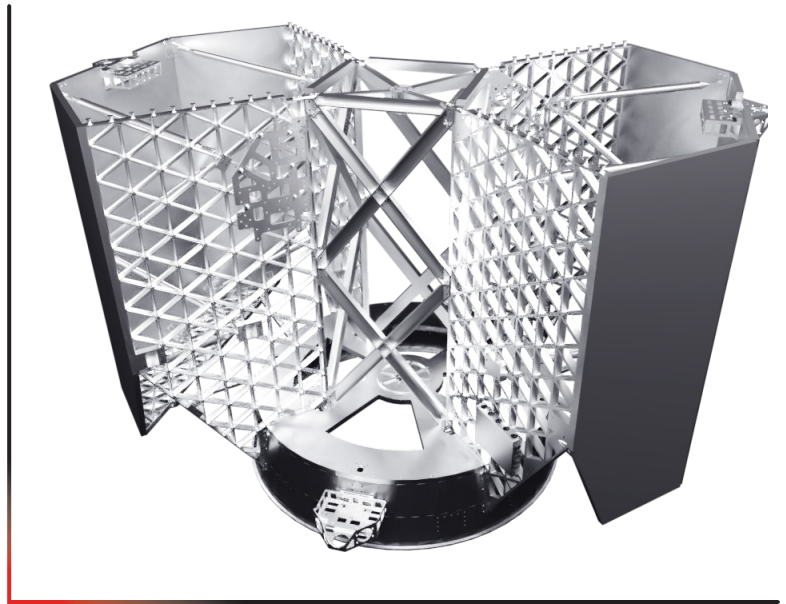

*Peregrine Structural Bus*

# PROPULSION

The Peregrine propulsion system features five main engines and twelve Attitude and Control System (ACS) engines powered by a pressure-fed hypergolic bipropellant, which does not require ignition because the fuel and oxidizer combust on contact. The system features a proven hydrazine derivative, Mono-Methyl-Hydrazine (MMH), as the fuel. The oxidizer is a solution of nitric oxide in dinitrogen tetroxide/nitrogen dioxide, 25% Mixed Oxides of Nitrogen (MON-25).

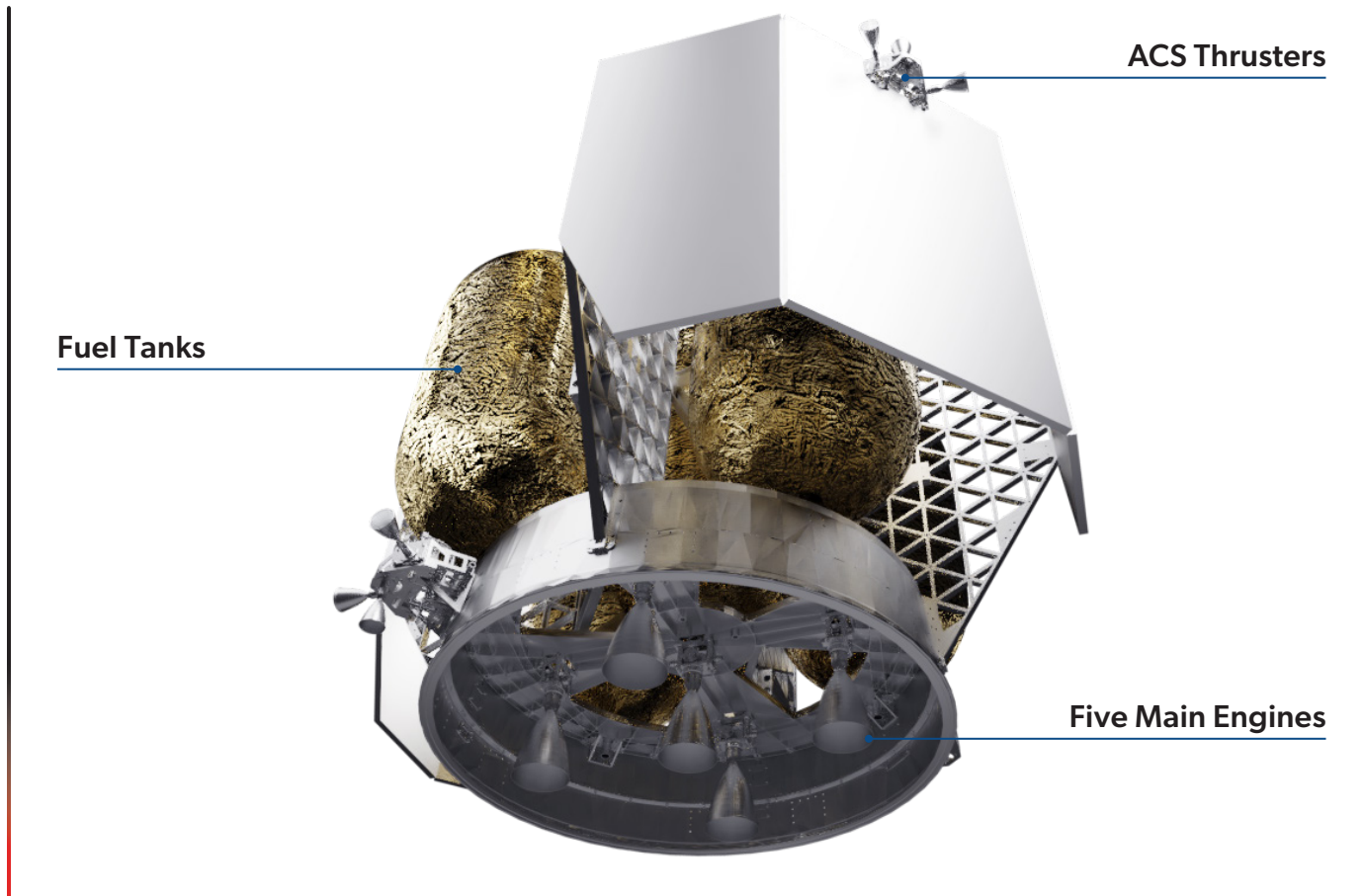

*Peregrine Propulsion Bus*

Two tanks each of the fuel and oxidizer are spaced evenly about the craft with a fifth tank for the Helium pressurant in the center. Peregrine's main engines, located within the cone, are used for all major maneuvers. Each of the engines produces 667 N of thrust and is pulsed for throttling. The ACS thrusters, grouped in clusters of three and placed about the lander to ensure control with six degrees of freedom, maintain lander orientation throughout the mission. The ACS engines each generate 45 N of thrust.



# GUIDANCE, NAVIGATION, AND CONTROL

Peregrine's Guidance, Navigation, and Control (GNC) system orients and flies the lander throughout the mission to facilitate operations. GNC processes the inputs from an array of sensors, correcting for idiosyncrasies, and uses them to revise the internal estimate of the lander's position, attitude, and velocity during flight. Commands to maneuver the lander are updated based on this estimate of the spacecraft's state. Earth-based ranging informs position and velocity state estimates for orbital and trajectory correction maneuvers.

Input from the star tracker, sun sensors, and inertial measurement unit aid the GNC system in maintaining a sun-pointing orientation, with the solar panel facing the Sun, during nominal cruise operations. During landing operations, a Doppler LiDAR provides range and range rate information that guides the lander to a safe landing at the target site.

## OPTICAL PRECISION AUTONOMOUS LANDING SENSOR

Astrobotic leads a team comprised of Moog Space and Defense, Moog Broad Reach, NASA Jet Propulsion Laboratory (JPL), and NASA Johnson Space Center (JSC) developing the Optical Precision Autonomous Landing (OPAL) Sensor. The OPAL Sensor is an imaging-based terrain relative navigation package that will be flown as a technology demonstration on Mission One and then incorporated with the GNC system on the following missions. The OPAL Sensor consists of a camera and high performance computer, which uses images from the camera and maps stored in the lander memory to estimate the pose of the lander in real time.



*OPAL Sensor Assembly*





# POWER

The lander power system is responsible for power storage, generation, distribution, and management. The system is designed to be power positive, generating more power than it uses, for all phases of flight except for descent to the lunar surface where the lander relies on battery power for a short period.

Peregrine stores energy in a space-grade lithium-ion battery. A panel of GaInP/GaAs/Ge triple junction solar cells with heritage in orbital and deep space missions generates the lander's power. The battery feeds into a 28 Vdc power rail from which unregulated and regulated power is distributed to all lander subsystems and payloads. The battery is utilized during quick discharge activities, such as engine burns and attitude maneuvers, and during phases of the mission where the solar panel is not generating power, such as in lunar shadow.

While in orbit, the solar panel is nominally pointed towards the Sun to enable maximum power generation. The solar panel is utilized to provide battery charge and maintain lander and payload operations. After descent to the lunar surface the power system continues to provide reliable power services to payloads through the end of mission.

## SOLAR PANEL CONFIGURATIONS

Missions to different latitudes on the lunar surface require that the solar panels used on Peregrine be reconfigured to optimize power generation. Mid-latitude and equatorial landers utilize top-mounted panels whereas polar missions utilize side-mounted panels. Landers with side-mounted panels perform a thermal control roll during transit to ensure consistent power generation.

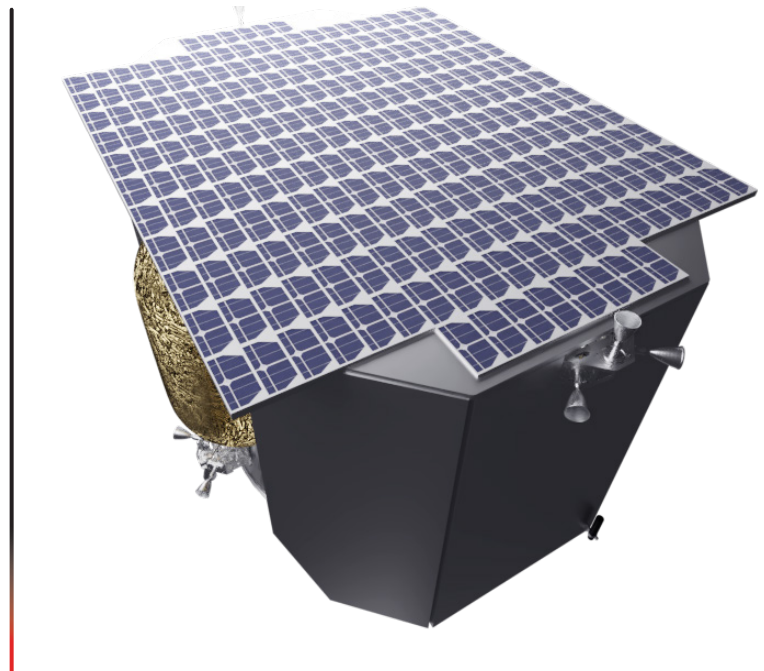

*Peregrine Mid-Latitude Solar Panel Configuration*



# AVIONICS

Peregrine's avionics perform all command and data handling for the lander, managing the various inputs and outputs of the lander's subsystems. The Integrated Avionics Unit (IAU) houses ten modules, or boards, with distinct functionalities encompassing the major aspects of the avionics system like the power management systems and the flight computer.

Other aspects, such as GNC flight sensor drivers and propulsion control units, are enclosed separately near the relevant subsystem hardware. Peregrine's flight computer consists of a 32-bit high-performance dual-core LEON 3 FT microprocessor. The computer employs radiation-hardened integrated circuits as well as fault-tolerant and SEU-proof characteristics.

## THE PAYLOAD COMPUTER

The payload computer, a pair of radiation-tolerant FPGAs, is also housed within the IAU and manages the individual payloads as well as their contractual services. The payload computer monitors payload power consumption and communicates directly with the payloads. Commands from the payload ground software are sent to the payload via the payload computer and payload telemetry is packaged for downlink to Earth. The payload computer features Error Detection And Correction, upset monitoring, and robust software with proven networking standards.

## FLIGHT HERITAGE

Peregrine's avionics system is designed to be modular and reusable; this enables future Peregrine missions to leverage the lessons learned and hardware developed for Mission One. While missions will utilize different lander configurations, the core command and data handling system remains the same, maintaining reliability for the product line.

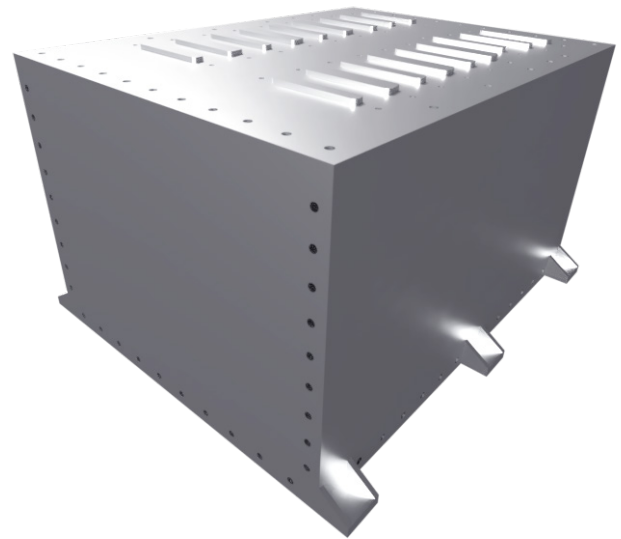

*Integrated Avionics Unit (IAU) Enclosure*



# COMMUNICATIONS

Peregrine’s communications system provides for lander commanding and telemetry. The communications system also relays data between the payload customer and their payload throughout the mission. The lander houses a high-powered and flight-heritage transponder to communicate with Earth. The lander-Earth connection uses different frequencies within the X-Band range for uplink and downlink space communications.

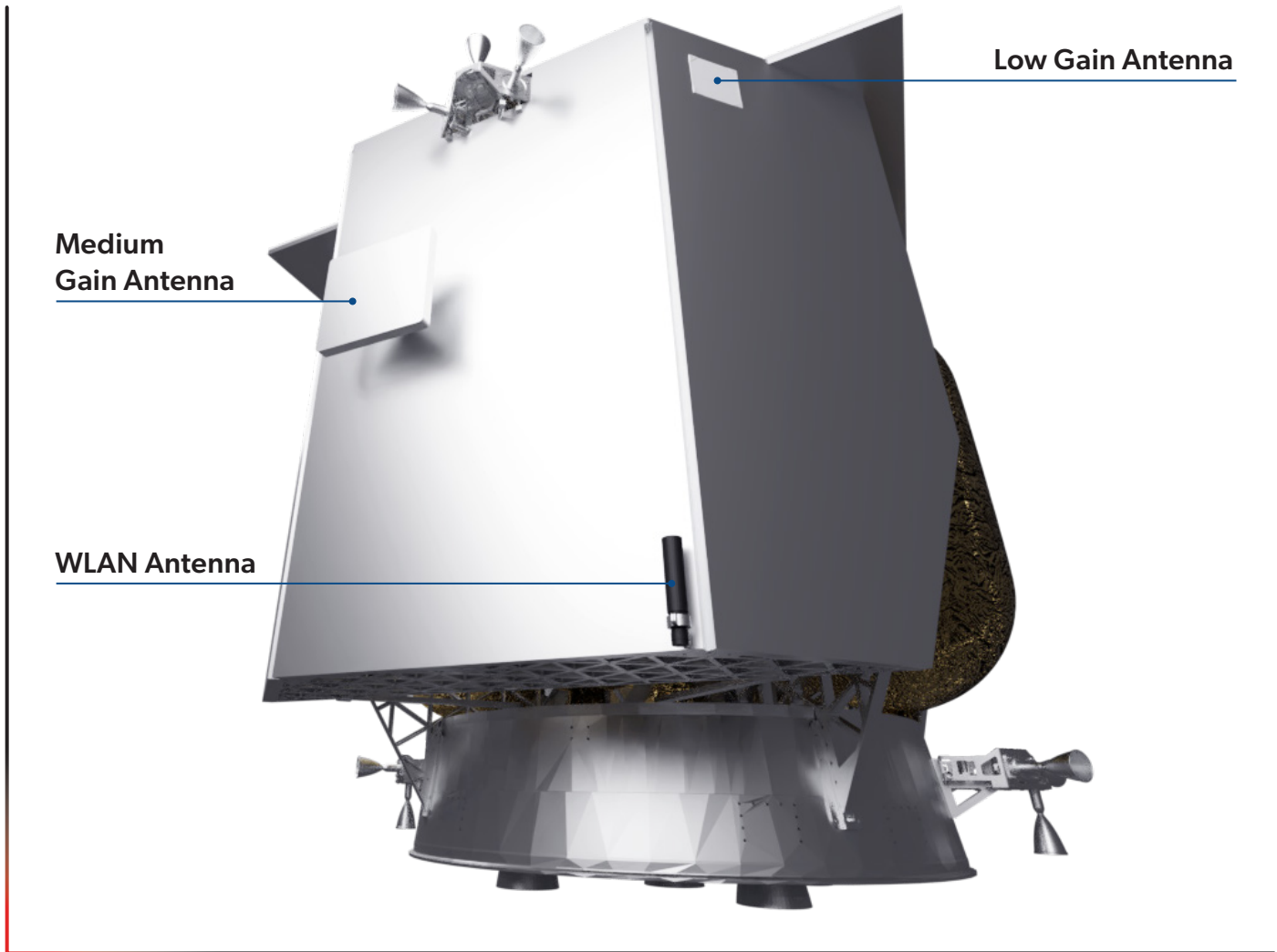

*Peregrine Communications Bus*

The lander utilizes multiple low gain antennas for optimal coverage during cruise and lunar orbit operations and then switches to an actuated medium or high gain antenna following touchdown on the lunar surface for increased bandwidth. The lander-payload connection is provided via Serial RS-422 or SpaceWire for wired communication throughout the mission. Following landing, a 2.4 GHz IEEE 802.11n compliant WLAN modem enables wireless communication between the lander and deployed payloads on the lunar surface. Peregrine relays payload telecommands and telemetry in near real-time.



# THERMAL CONTROL

The lander is designed to implement mainly passive methods to regulate its thermal environment. Radiators are used to amass excess heat and radiate it out into space. Passive heat pipes are employed to direct excess heat to colder regions of the lander where it is needed. Layers and coatings, such as Multi-Layer Insulation (MLI), are used to protect components from undesired external thermal effects.

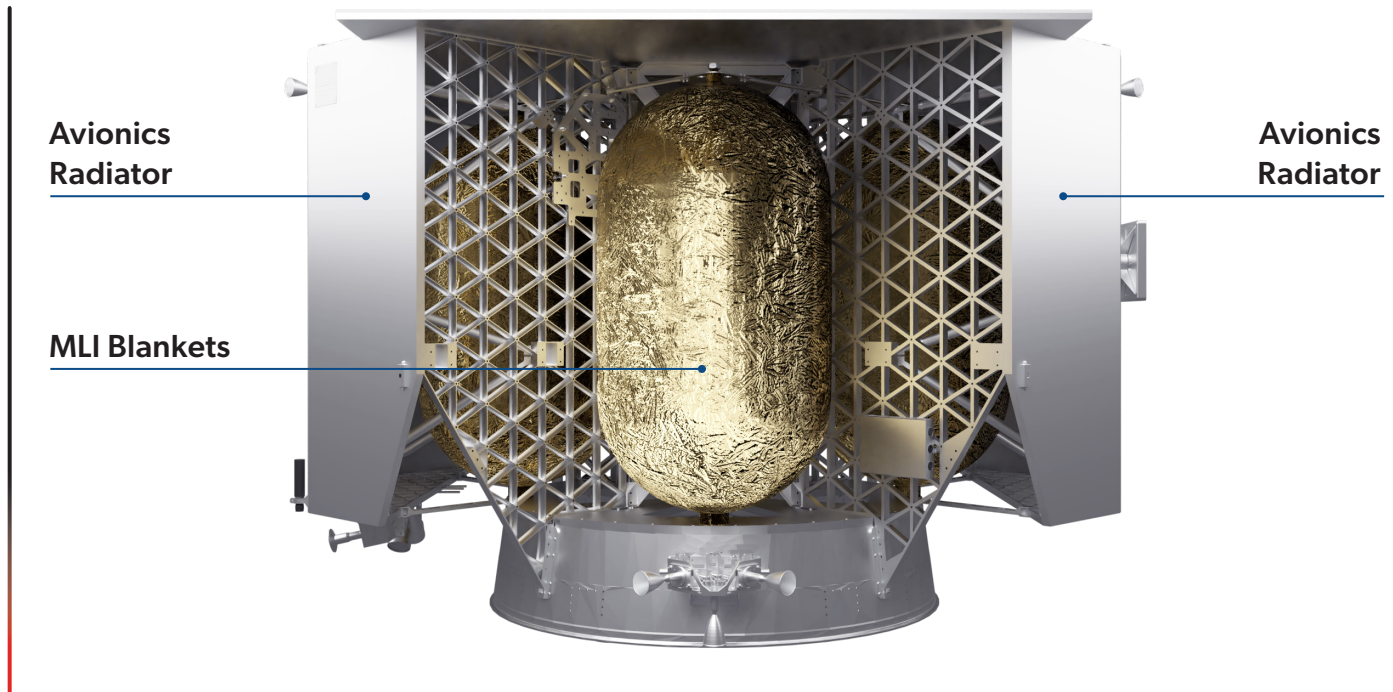

*Peregrine Thermal Bus*

Some active thermal control methods, heating or cooling, may be implemented to maintain particularly stringent thermal conditions of sensitive critical components. The overall thermal design is highly mission-specific as the lander may be either hot or cold-biased depending on the extreme thermal case of each mission profile.



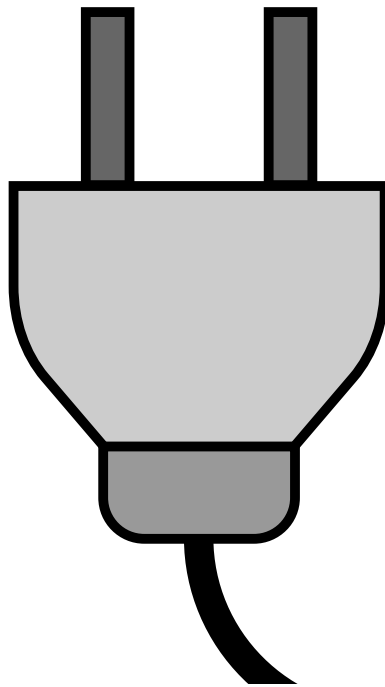

# INTERFACES

# MECHANICAL ENVIRONMENT

The Peregrine mechanical environment is enveloped by the launch phase. The following environments are based on the mid-latitude configuration of Peregrine. These environments envelope 90% of payload mounting locations; however, mission-specific configurations and payload placement may impact expected loads. Astrobotic works with each customer to develop payload-specific environments for relevant testing and analysis prior to integration.

## SINE VIBRATION LOADS

Static axial and lateral accelerations are enveloped by the sine vibration environment. Astrobotic performs a coupled loads analysis with the launch vehicle provider and develops sine vibration loads for each payload based on mounting location, payload mass properties, launch vehicle, and the specific lander configuration. Please contact Astrobotic for more details on sine vibration loads.

## RANDOM VIBRATION LOADS

The random vibration loads for payloads are derived from the lander structure due to the acoustic environment. These are the qualification loads for random vibration in all axes, a duration of 2 minutes per axis may be assumed.

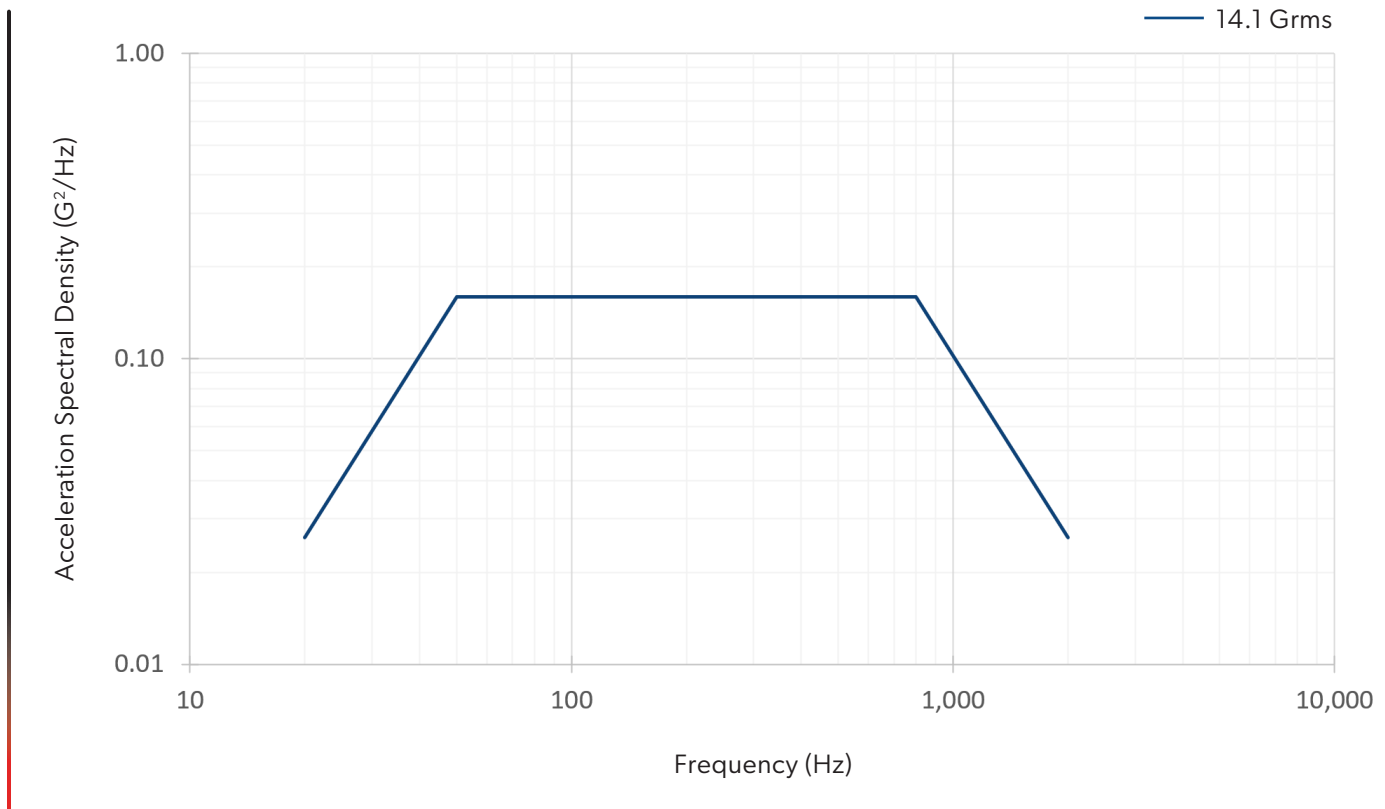

## ACOUSTIC LOADS

Payloads are subjected to the highest acoustic levels at lift-off and during transonic flight. The expected duration of these loads is less than 2 minutes. The acoustic qualification loads are shown below.

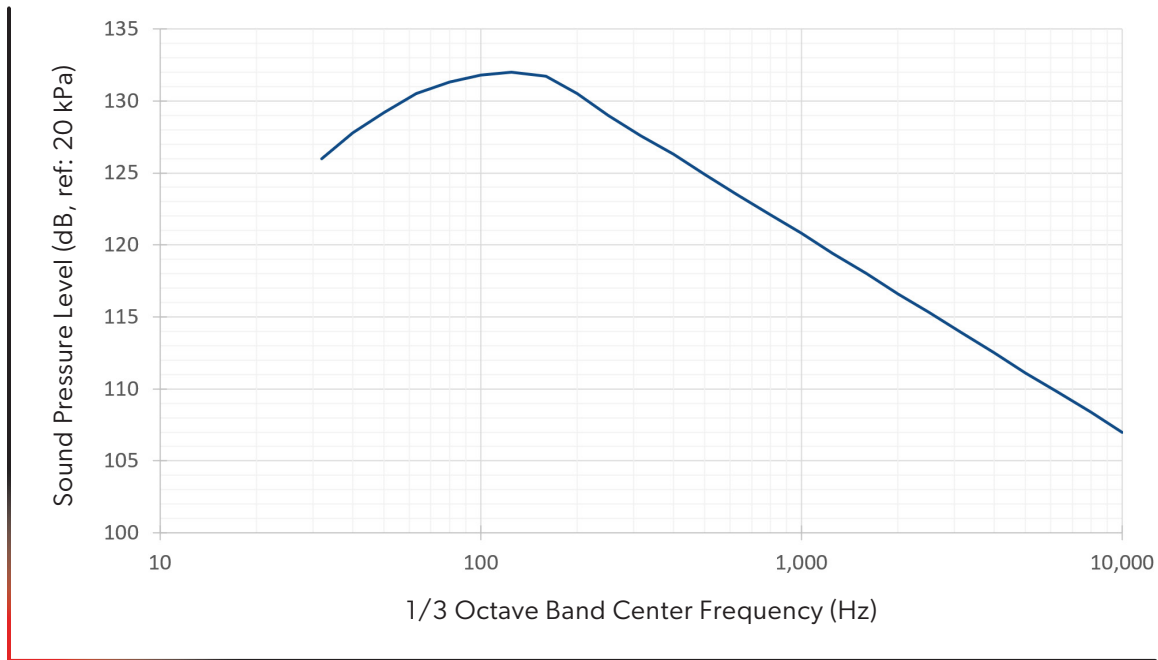

## SHOCK LOADS

Peregrine encounters multiple shock events during launch and injection. Shock events include the launch vehicle fairing release, lander separation, and landing. Payloads may assume 5 shock events with qualification loads as follows.

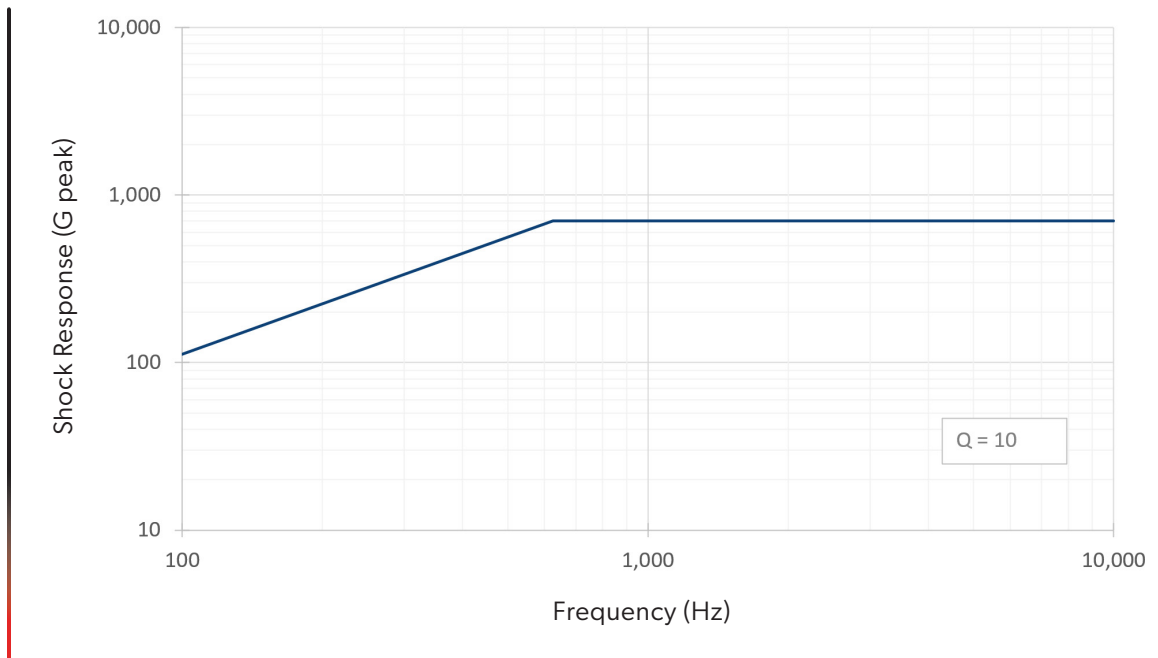

NOTE: Payloads may reference GSFC-STD-7000A (GEVS) for more details on payload random, shock, and acoustic environments.



# THERMAL ENVIRONMENT

Peregrine encounters the following approximate thermal environments on a typical reference mission.

**0°C to 27°C    PRE-LAUNCH**

The integration and launch facilities are climate-controlled to provide this specific temperature range.

**0°C to 27°C    LAUNCH**

Throughout the Launch phase, the integrated Lander is encapsulated in an environmentally controlled launch vehicle payload fairing.

**-40°C to 60°C    CRUISE**

The thermal environment is significantly colder for objects in shadow and much hotter for objects in direct sunlight.

**-120°C to 100°C    LUNAR ORBIT**

The thermal environment is significantly colder for objects in shadow, particularly during lunar eclipse, and much hotter for objects in direct sunlight, which can be compounded by light and infrared radiation from the lunar surface.

**-30°C to 80°C    LUNAR SURFACE**

The thermal environment is significantly colder for objects in shadow and much hotter for objects in direct sunlight. This range is relevant for the nominal lunar surface operations duration and does not include lunar night or missions to equatorial latitudes.

*NOTE: The corresponding thermal environments of the payload depend on mounting location and the incident sunlight at that location throughout the mission. Astrobotic works with each customer to develop payload-specific environments for relevant system testing prior to payload integration.*





Throughout flight, Peregrine is nominally oriented with the top-mounted solar panel facing the Sun. As a result, the lander’s top-side receives the most incident solar radiation, and resulting heat, during the Cruise and Lunar Orbit phases. Polar configurations by contrast perform a thermal control roll during Cruise and Lunar Orbit, evenly heating the spacecraft and pointing the solar panels at the Sun.

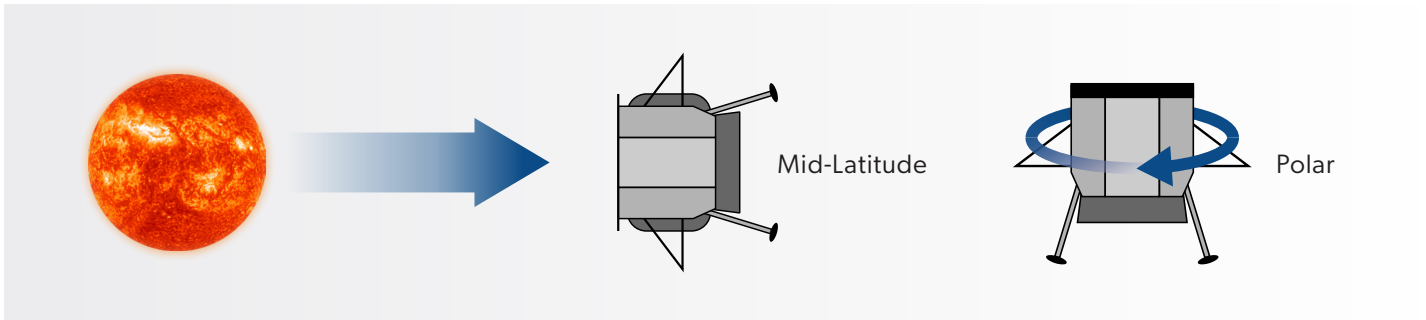

The most extreme thermal environments occur during the Lunar Orbit phase when the lander cycles through cold and hot as it passes through the Moon’s shadow, shown in the representative diagram below. Peregrine nominally spends up to 24 hours in LO1 and 72 hours in LO3. The duration in LO2 is dependent on the trajectory and orbital deployment concept of operations.

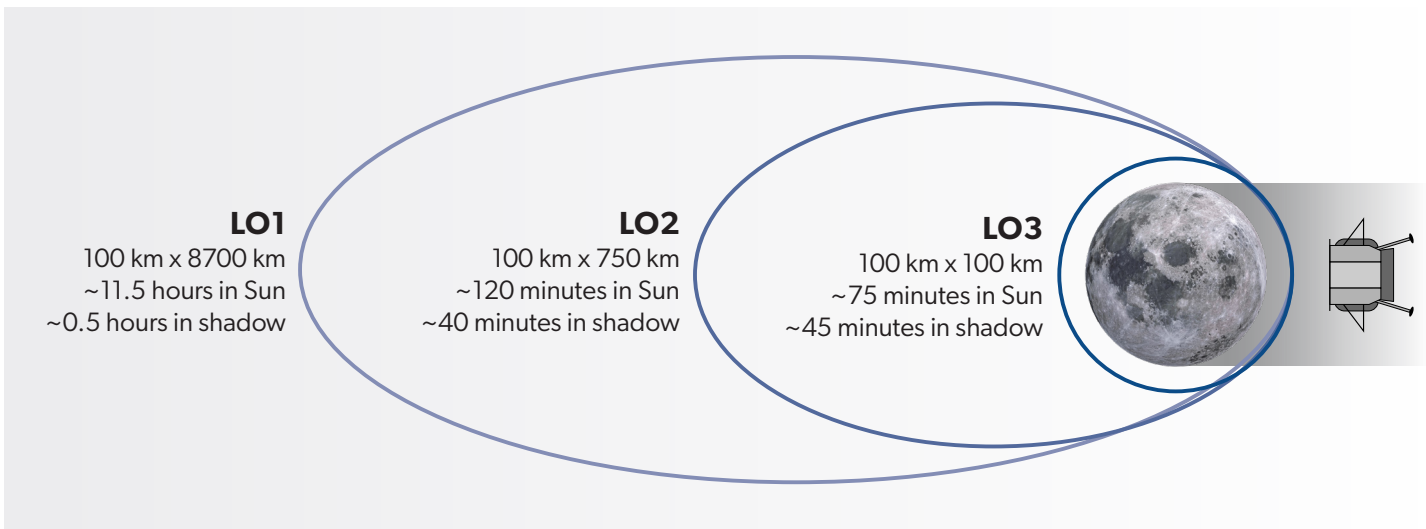

On the Lunar Surface, Peregrine is nominally oriented such that the avionics in Enclosure A are pointed towards the lunar north pole where it is mostly or completely shadowed for the duration of lunar surface operations.

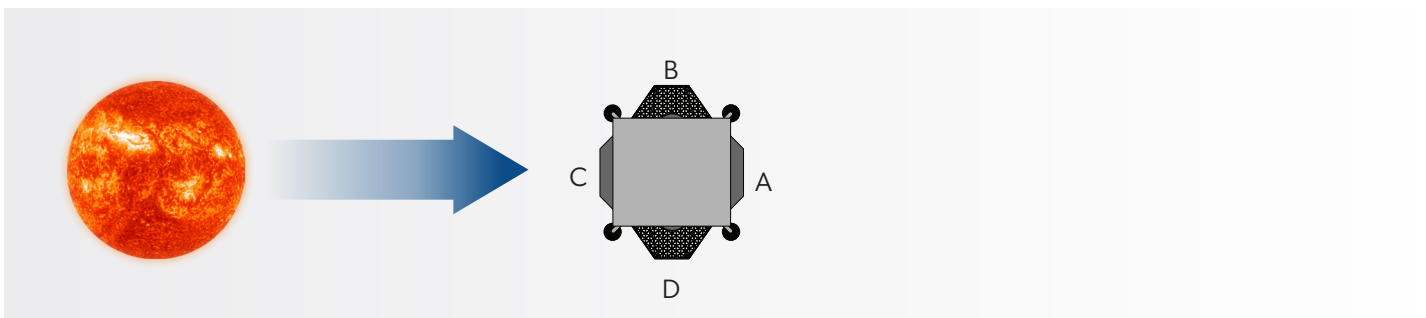

The movement of the Sun throughout the lunar day and the reflection of light from the lunar surface creates thermal environments highly specific to the payload’s mounting locations.



# PRESSURE AND HUMIDITY ENVIRONMENT

## PRESSURE ENVIRONMENT

Peregrine encounters the following approximate pressure environments on a typical reference mission.

### PRE-LAUNCH

101.25 kPa represents the average atmospheric pressure at sea level; the actual value depends on the respective locations of the integration and launch facilities.

### LAUNCH

This is a typical pressure drop curve for launch which envelopes the pressure drop for all other mission phases. The pressure drop is expected to surpass  $-2.5$  kPa/s only briefly during transonic flight as the launch vehicle exceeds the speed of sound and will not exceed  $-5.0$  kPa/s.

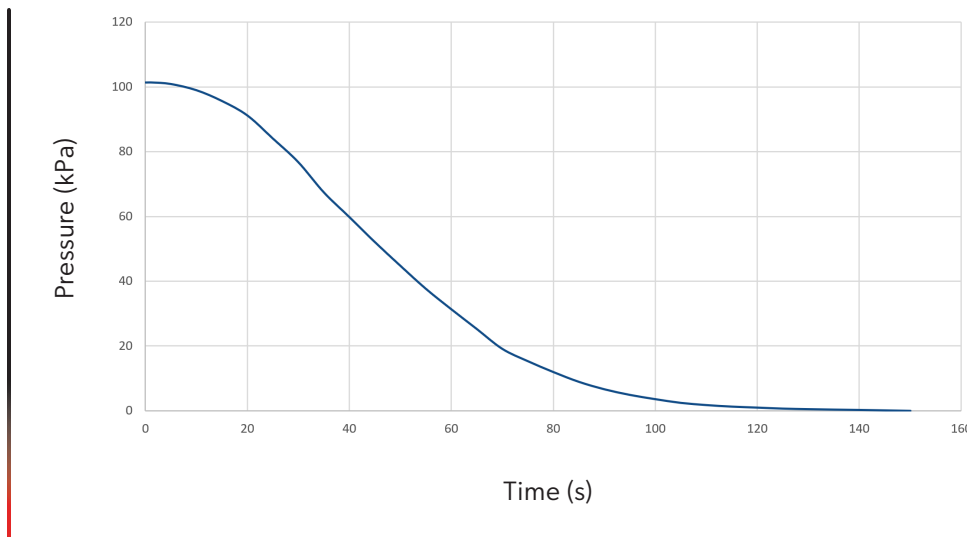

### REMAINING MISSION

$3.2 \times 10^{-5}$  kPa represents the vacuum of the space environment.

## HUMIDITY ENVIRONMENT

Peregrine encounters the following approximate humidity environments while on mission.

### LAUNCH

The integration and launch facilities are climate-controlled to  $50\% \pm 15\%$  humidity. The higher humidity values may occur during transportation and depend on the local climate of the facilities' locations.

### REMAINING MISSION

The vacuum of the space environment has 0% humidity.



# PARTICLE AND CONTAINMENT ENVIRONMENT

The Peregrine encounters the following approximate particle and contaminant environments on a typical reference mission.

## PRE-LAUNCH

Planetary Protection regulations govern the Pre-Launch particle and contaminant environment. Assembly and maintenance of the lander and payloads must occur in a 100k or ISO Class 8 cleanroom. The integration and launch facilities provide suitable cleanrooms for Pre-Launch activities. The payload customer must ensure compliance with Planetary Protection protocols prior to integration with the lander.



*Astrobotic Headquarters and Integration Facility contains two ISO Class 8 cleanrooms for Integration.*

## CRUISE, LUNAR ORBIT, AND SURFACE

The firing of main and thruster engines expels a minute amount of propellant. Following touchdown on the lunar surface, the propulsion system is made safe by venting excess helium pressurant, which may carry trace amounts of fuel and oxidizer. These propellant residuals are unlikely to affect payloads; however, payload customers may design for shielding of sensitive components if so desired.

## SURFACE

During the landing procedure, Peregrine displaces an unknown amount of lunar regolith, which may take several hours or days to fully settle. Lunar regolith is sharp and may cause damage to sensitive components. Lunar regolith is also electrostatically charged, which may cause it to cling to payload surfaces. The payload customer is responsible for identifying at-risk payload systems and implementing mitigation strategies such as shielding or deployable dust covers if necessary.



# RADIATION ENVIRONMENT

Peregrine encounters the following approximate ionizing radiation environments on a typical reference mission. The Van Allen radiation belts contain energetic protons and electrons that are trapped in the Earth's magnetic field and generally follow the magnetic field lines. The overall structure of the Van Allen belts can be seen from the highly simplified diagram in the figure below.

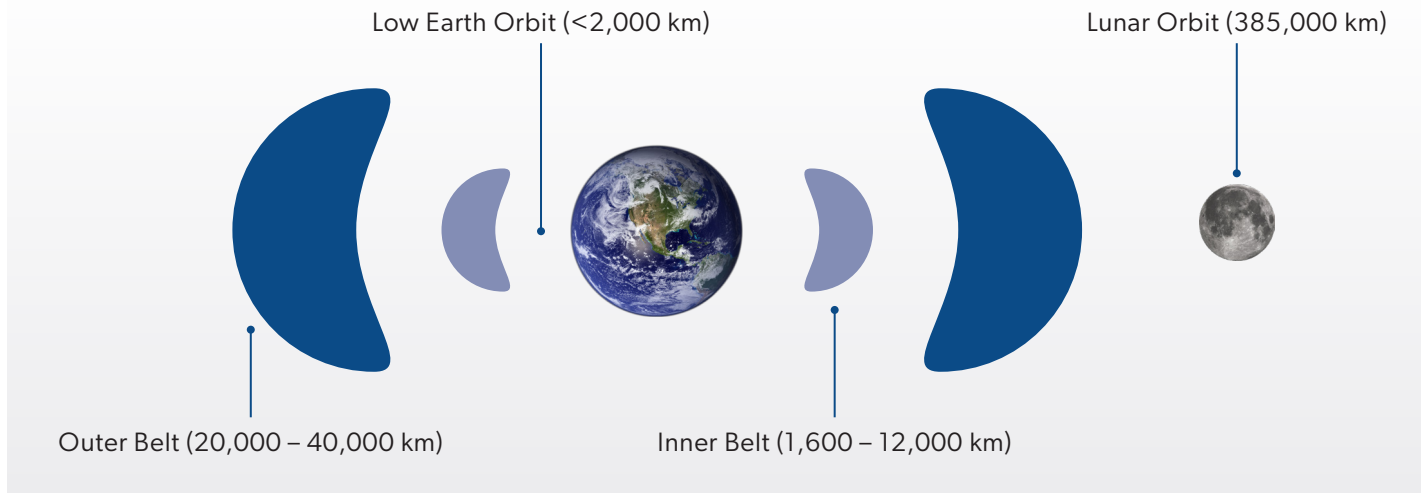

Peregrine may experience 3 to 15 days in the near-Earth environment, during the Launch and Cruise phases, and 14 to 38 days in the interplanetary environment, from Cruise phase onwards. The final trajectory depends on the launch date selected by the launch vehicle's co-manifested payload.

## NEAR-EARTH ENVIRONMENT

The near-Earth environment is defined by the trapped radiation within the Van Allen belts and is expected to be 20 rads/day. This ionizing dosage is based on expected electron as well as heavy ion and proton radiation per Earth day in the near-Earth environment.

## INTERPLANETARY ENVIRONMENT

The interplanetary environment is defined as outside of the shielding effects of Earth's magnetic field. An ionizing dosage of 1 rad/day is predicted based on expected electron radiation per Earth day in the interplanetary environment.

## TOTAL IONIZING DOSAGE

The total ionizing dosage typically is not expected to exceed 1 krad. The lander is designed to mitigate destructive events within its own electronics caused by nominal radiation for a period of eight months.

*NOTE: These values do not take into account the potential for a solar particle event.*



# ELECTROMAGNETIC ENVIRONMENT

The lander and all payloads must be designed for compliance with MIL-STD-461G for radiated and conducted emissions. The table below shows the appropriate testing to perform based on payload type, defined on the following page. Please contact Astrobotic for additional information or the latest version of the relevant Requirements for the Control of Electromagnetic Interference Emissions and Susceptibility (MIL-STD-461G) document.

| EMI CATEGORY                    | REQUIREMENT                      | APPLICABILITY          |
|---------------------------------|----------------------------------|------------------------|
| <b>Conducted Emissions</b>      | CE102                            | Active Payloads        |
| <b>Conducted Susceptibility</b> | CS101<br>CS114<br>CS115<br>CS116 | Active Payloads        |
| <b>Radiated Emissions</b>       | RE102                            | Active Payloads        |
| <b>Radiated Susceptibility</b>  | RS103                            | Payloads with Antennas |

These tests characterize the interference, susceptibility, and compatibility of the lander and payloads to ensure appropriate electrical interfacing that does not induce significant interference, noise, or performance degradation into the integrated system. Additionally, these tests inform compliance with other external standards and regulations such as Range Safety. Please contact Astrobotic for the latest version of the relevant Range Safety User Requirements Manual Volume 3 (AFSCMAN91-710V3) document.



# PAYLOAD TYPES

Astrobotic recognizes four payload types. A payload may be either passive or active as well as either static or deployable; this results in the four distinct payload types detailed below. The standard payload interfaces, services, and operations are informed by the payload type.

|         | STATIC   | DEPLOYABLE  |
|---------|--|---|
| PASSIVE | <p><b>Static Passive</b></p> <ul style="list-style-type: none"> <li>• Remains attached to lander</li> <li>• Does not perform mission tasks</li> </ul> <p><i>Example: Memorabilia</i></p> | <p><b>Deployable Passive</b></p> <ul style="list-style-type: none"> <li>• Detaches from lander</li> <li>• Does not perform mission tasks</li> </ul> <p><i>Example: Surface time capsule</i></p> |
| ACTIVE  | <p><b>Static Active</b></p> <ul style="list-style-type: none"> <li>• Remains attached to lander</li> <li>• Performs mission tasks</li> </ul> <p><i>Example: Science instrument</i></p>   | <p><b>Deployable Active</b></p> <ul style="list-style-type: none"> <li>• Detaches from lander</li> <li>• Performs mission tasks</li> </ul> <p><i>Example: Rover</i></p>                         |

Peregrine provides payloads with standard and well-defined interfaces to support their missions. The following pages outline the standard physical, functional, and ground segment interfaces for payloads. The service interfaces, which provide power and data to payloads, vary both by payload type and mission phase. Service interfaces are described in the Mission Operations section. Astrobotic is able to accommodate nonstandard interfaces upon request.

Please contact Astrobotic for additional information or the latest version of the Interface Definition Document (IDD), which provides a comprehensive description of the standard interfaces.



# PAYLOAD MOUNTING ACCOMMODATIONS

Peregrine accommodates a wide range of payloads by providing a flexible mounting solution to accommodate payload pointing and mounting requirements. Two open isogrid aluminum decks serve as the standard payload mounting structure, a smaller deck is utilized for some deployable payloads. Alternate mounting locations, such as on the vertical enclosures or internal shear panels, are available as a nonstandard service; please contact Astrobotic for additional information.

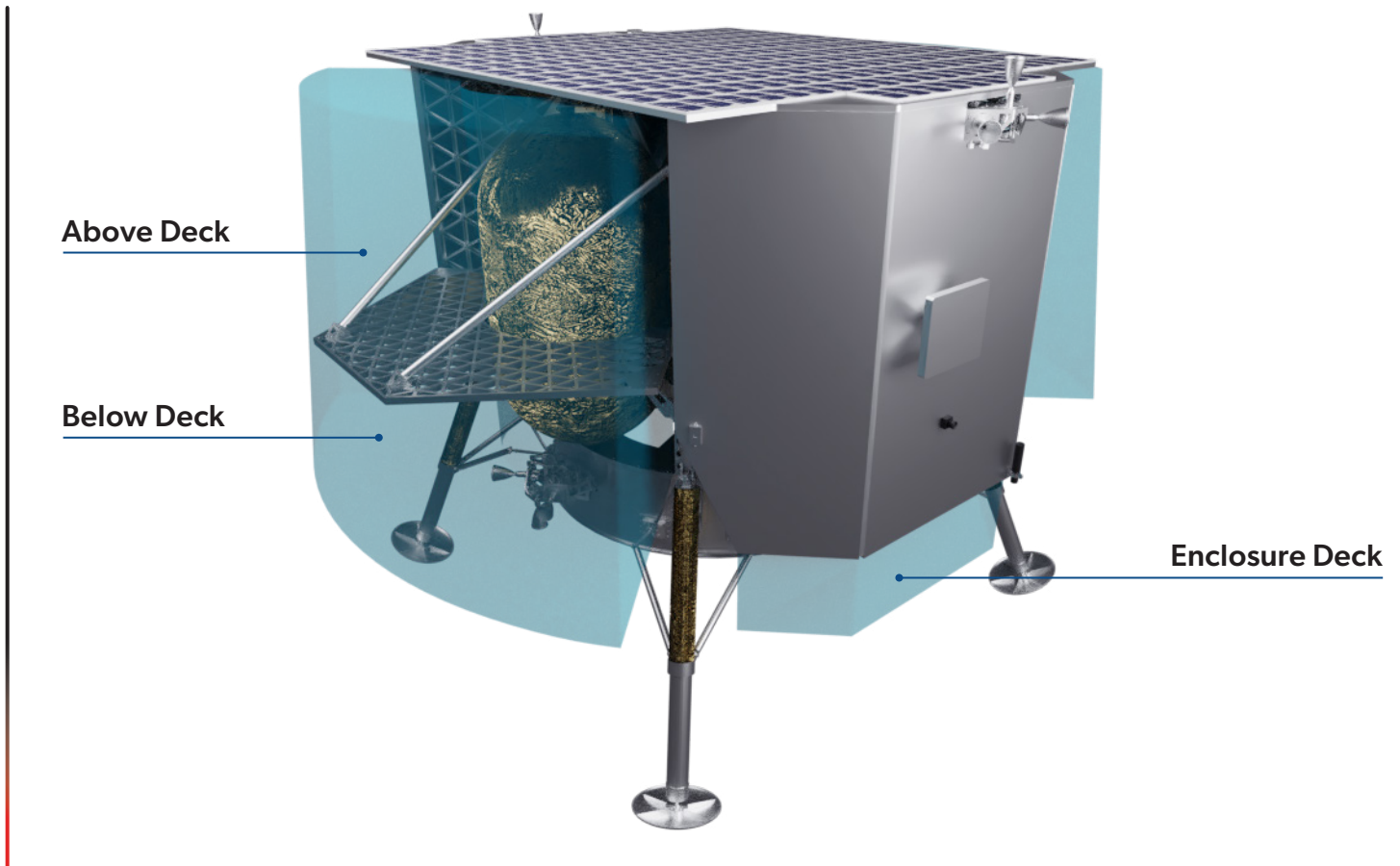

*Standard Payload Mounting Envelopes*

Astrobotic provides a volume about the payload mounting decks designated for safe and simple accommodation of payloads, known as the payload envelope. The envelope ensures safe stowage during flight and sufficient ground clearance upon landing for payloads. Astrobotic works with each payload customer to define a section of this envelope, which the payload may use as desired.

As a standard service, Astrobotic can accommodate payloads up to 0.38 m tall below the payload mounting decks and 0.57 m tall above the decks. Depending on the landing conditions, the ground clearance from the bottom of the payload envelope ranges between 0.40 m and 0.80 m.

Payload operations outside of the envelope are permitted during the Surface phase. Such operations must be discussed and scheduled with Astrobotic. Egress procedures may also be performed during the Lunar Orbit phase as discussed and scheduled with Astrobotic.



# PAYLOAD MOUNTING DECKS

The payload mounting decks are the primary mounting location for payloads, featuring a standardized bolt pattern for simplified payload mounting. Most Peregrine configurations feature two standard decks and a deck below one avionics enclosure for smaller payloads.

Each standard deck offers approximately  $0.5 \text{ m}^2$  of mounting area per side. The same bolt pattern is provided on both sides of these decks. Locking helicoil inserts are sized for standard M5 bolts and are spaced  $75 \text{ mm}$  apart, from center to center. The small deck features approximately  $0.2 \text{ m}^2$  of mounting area and payloads may only mount below the deck.

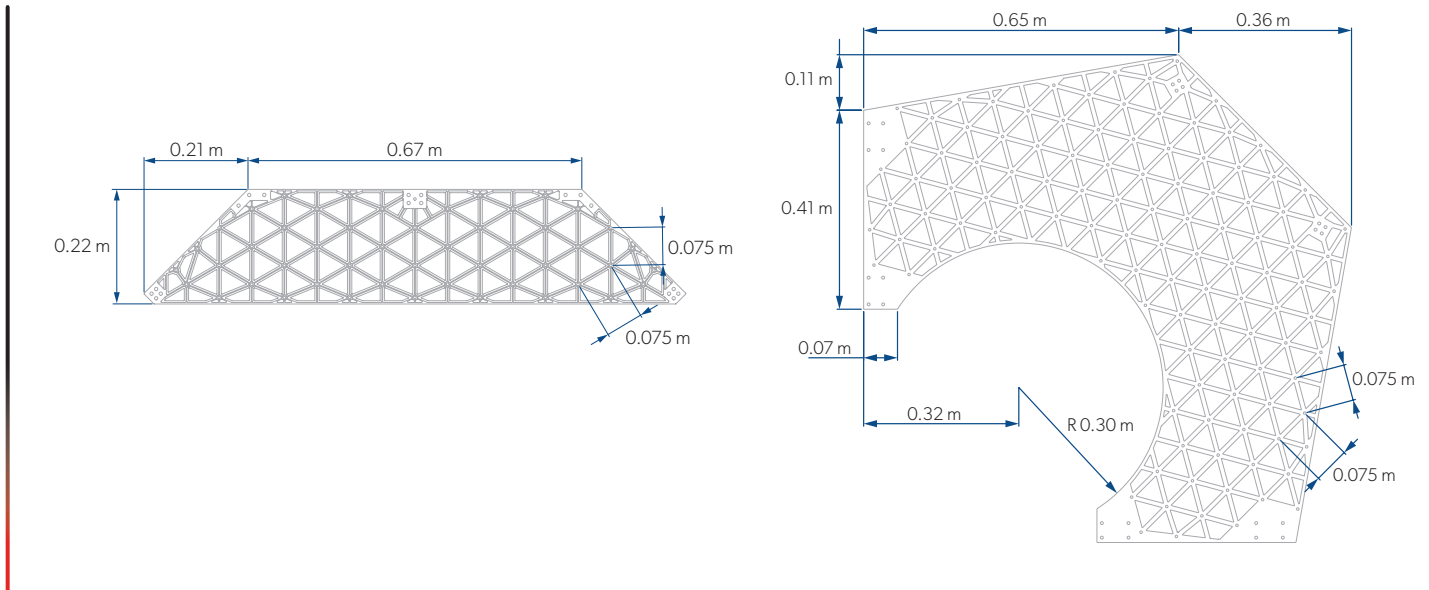

Please contact Astrobotic for more detailed drawings and dimensions of the payload mounting decks.

Astrobotic assigns specific bolt holes to every payload based on their size and mounting location requirements. Astrobotic provides a suitable number of helicoil inserts to each payload as determined by the payload size and allotted number of bolt holes.

The appropriate method for attaching a payload to its assigned helicoil inserts is illustrated in the diagram to the right. The lander deck and Astrobotic-supplied helicoil inserts are shown in gray whereas customer-supplied components are shown in blue. Two payloads may utilize the same bolt hole from opposite sides of the deck as each side of the payload mounting deck is provided its own locking helicoil insert.

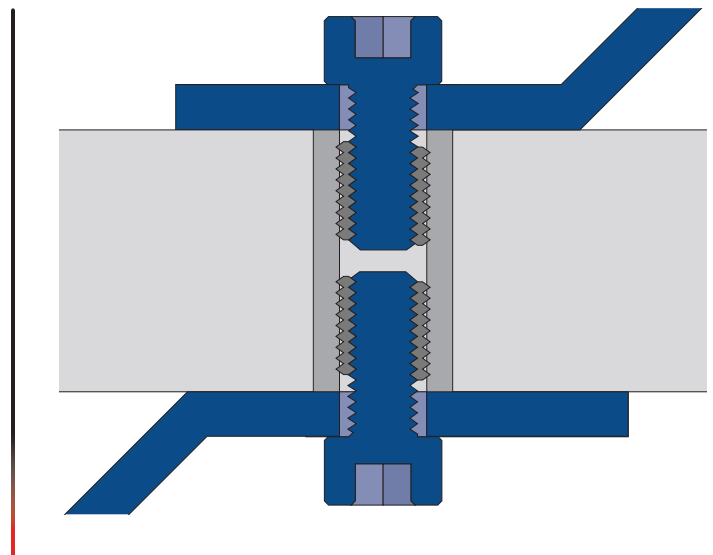



# ADAPTER PLATES

Payload placement on the lander is an iterative and cooperative process between Astrobotic and the payload customer. The final assignment of bolt holes to each payload occurs once the manifest is filled and ICD's are signed. Astrobotic recommends payloads utilize an adapter plate, which allows the payload design to progress independently of the assignment of bolt holes. The diagram below illustrates a typical payload adapter plate design. Adapter plates are considered part of a payload's mass allocation.

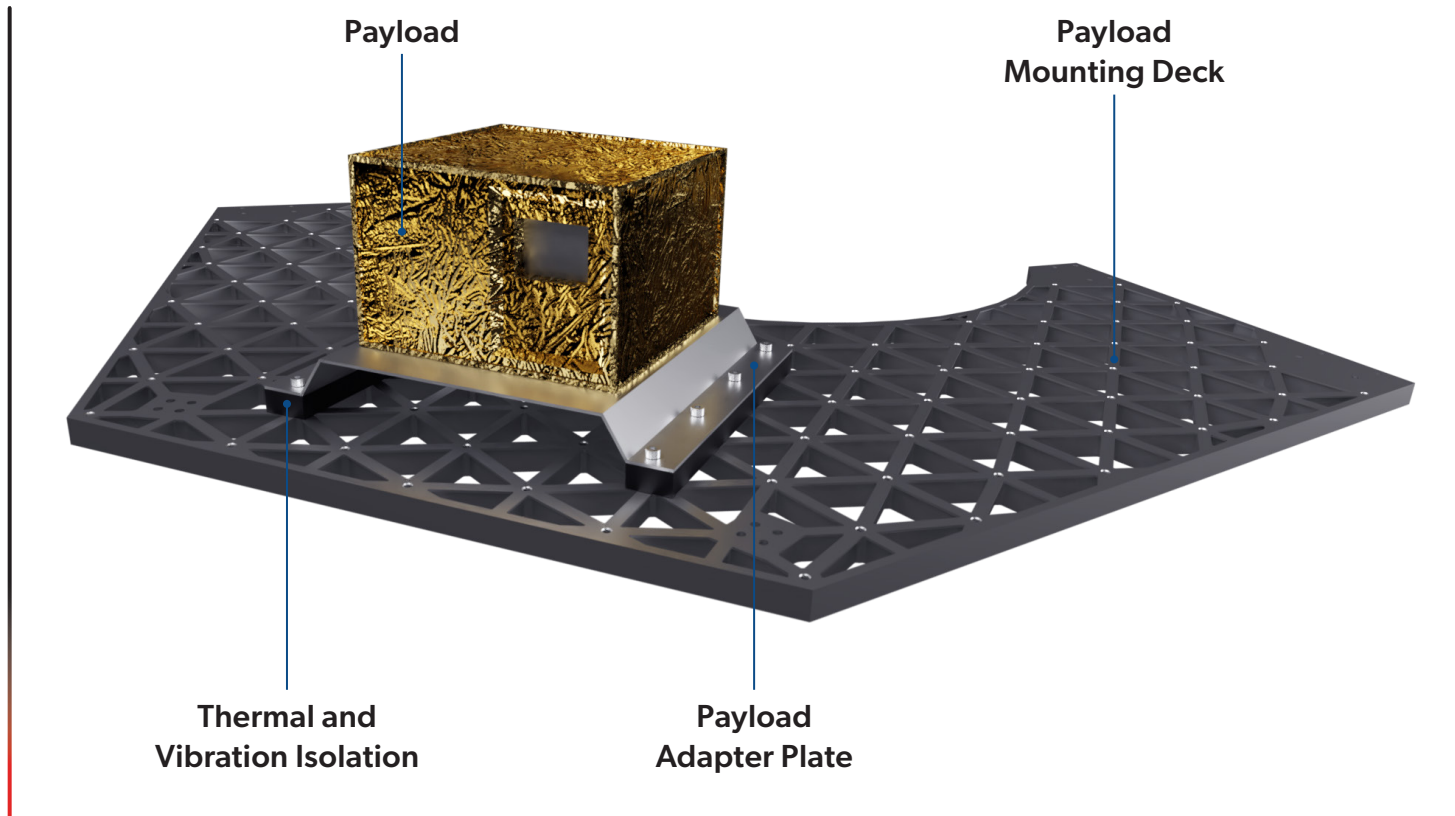

Additionally, the adapter plate can be utilized to dampen loads as experienced by the payload. It can also simplify the provision of the required thermal characteristics as well as the implementation of the required grounding, bonding, and isolation techniques at the payload mounting interface to the lander.

## THERMAL INTERFACES

The payload must implement a thermally isolating connection to the lander, defined as a conductance of  $< 0.1 \text{ W/K}$ . This allows the payload to more effectively regulate its own thermal environment using passive methods, such as radiators and coatings, or active methods, such as internal heaters.

## GROUNDING, BONDING, AND ISOLATION INTERFACES

Peregrine operates with a single-point ground architecture. Payloads must conform to this approach by employing proper grounding, bonding, and isolation schemes within their own payload design and by providing contact points for the payload structural and conductive elements as well as internal electrical circuit common ground, which Astrobotic connects to the lander chassis for grounding.



# ELECTRICAL INTERFACES

Astrobotic provides power and data services through a Standard Electrical Connector (SEC). The SEC is a Glenair SuperNine connector of the MIL-DTL-38999 Series III screw type connector. The connector is available in a regular and small size, each with a standard pin configuration providing the contacts illustrated below. Please contact Astrobotic for the specific SEC part number for your payload.

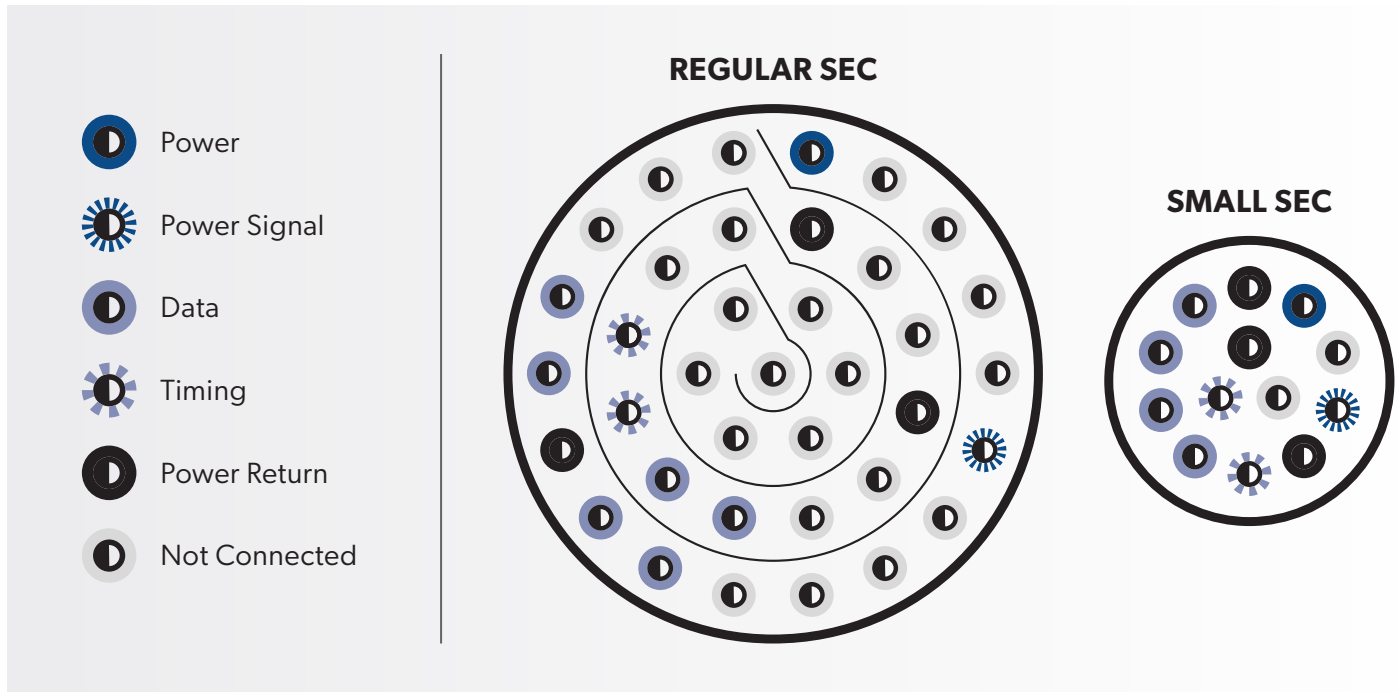

## POWER

Payloads are allocated two power circuits as a standard service. One is used for payload operations and if necessary, heater power. The other power circuit is used to perform deployments or actuations within the payload. The power provided is  $28 \pm 5\%$  Vdc and the power circuits are current-regulated, current-monitored, reverse-voltage protected, and over-voltage-protected.

## DATA

Data circuits are available in either Serial RS-422 or SpaceWire configurations. Both data circuits support time at the tone, a time synchronization service that enables payloads to synchronize their internal clock with the lander and by extension UTC time. Payloads requiring the use of SpaceWire for additional data bandwidth must use the regular size SEC.



# RELEASE MECHANISMS

Payloads may deploy from Peregrine in lunar orbit or on the lunar surface. Deployable payloads require a release mechanism to detach from the lander. The customer is responsible for the selection, procurement, testing, and integration of the release mechanism they deem most suitable for their payload design in accordance with the Astrobotic guidelines and requirements.

## LUNAR SURFACE DEPLOYMENTS

For lunar surface deployable payloads, Astrobotic recommends the use of hold-down and release mechanism style devices, but the customer may select the device most suited to the payload design if it meets the following requirements:

- Non-pyrotechnic
- Creates minimal debris
- Imparts no shocks greater than 300 g's on the lander upon actuation
- Is housed within the payload unit

## LUNAR ORBIT DEPLOYMENTS

Due to the mission-critical nature of orbital payload deployments prior to landing, Astrobotic requires the use of a proven release mechanism design for lunar orbit deployable payloads. Please contact Astrobotic for more details on lunar orbit deployable payloads.

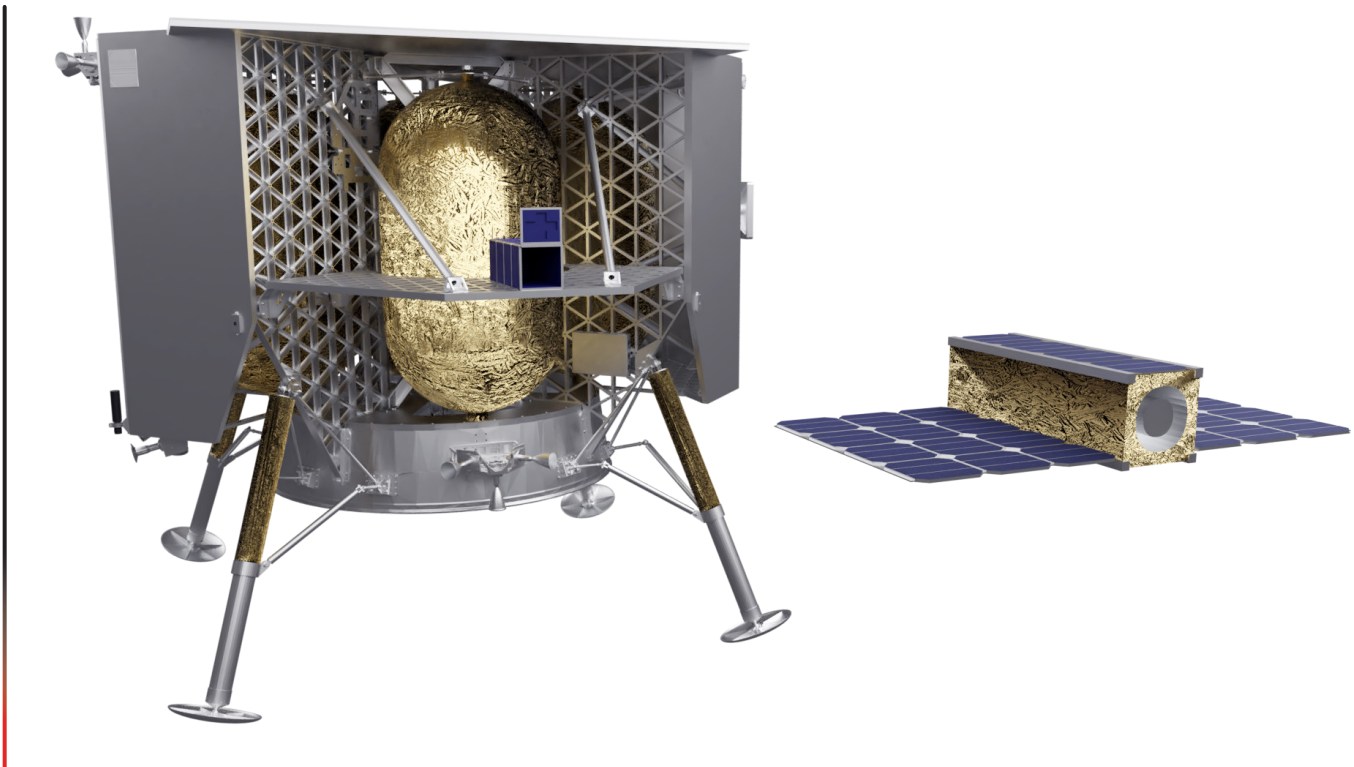

Peregrine provides power services and power release signal services to the SEC interface. The payload customer is responsible for integrating the release mechanism into their payload design such that it correctly interfaces with these provided services and employs the appropriate arm and fire techniques to satisfy Range Safety requirements. Please contact Astrobotic for the latest version of the Range Safety document.



# DATA INTERFACES

Peregrine uses standard, well-defined data interfaces to simplify payload integration. Wired data services are provided through the SEC. Therefore, wired data services are available only while the payload is attached to the lander. Wireless data services are available to surface deployable payloads following separation from the lander. Orbit deployable payloads must establish an independent communication connection with Earth following separation from the lander.

## NETWORK PROTOCOLS

Payloads may select between the three networking protocols to interface with the lander. Surface deployable payloads are recommended to select a wired data interface for communications prior to separation from the lander in addition to the wireless data interface.

- Serial RS-422, Serial Line IP (SLIP), and User Datagram Protocol (UDP)
- SpaceWire high-speed wired communication
- 2.4 GHz 802.11n WLAN wireless communication with IP and UDP

## NETWORK ARCHITECTURE

Payload telemetry and telecommands are transmitted from the lander to the Astrobotic Mission Control Center and then to the Payload Mission Control Centers without modification of payload data. Astrobotic contracts ground stations to communicate with Peregrine using X-Band for uplink and downlink. One-way latency in the connection between the customer and their payload on the Moon is nominally 4 seconds, although increases in latency may occur during some mission events.

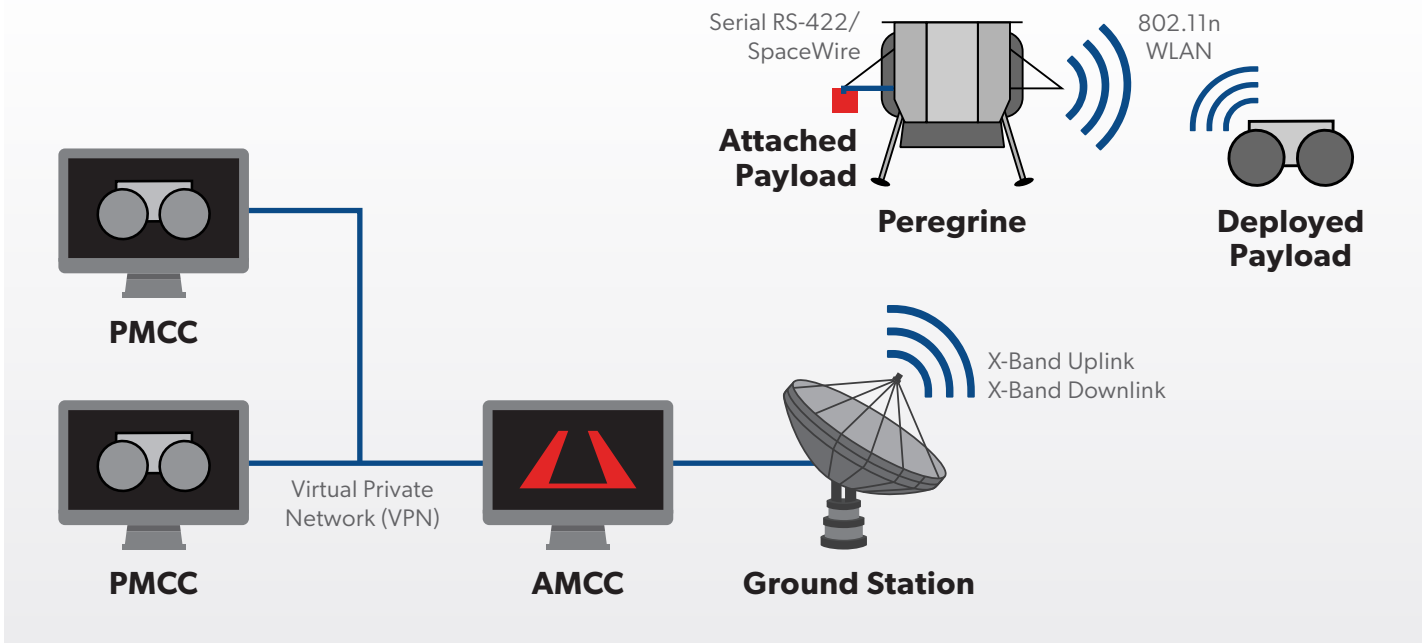

# GROUND SEGMENT

The Astrobotic Mission Control Center (AMCC) serves as the data hub for Peregrine missions, providing standardized, transparent, and safe networking to payload customers.

Payload Mission Control Centers (PMCCs) may be located adjacent to or remotely from the AMCC. Payload customers are given access to a secure and private part of the AMCC network via Virtual Private Network (VPN). Payloads that choose to operate their payloads adjacent to the AMCC do so from the Payload Operations Area. Customers may implement custom PMCC applications using whatever hardware or software is necessary to monitor and control the payload.



*Rendering of the Astrobotic Mission Control Center in Pittsburgh, PA.*

Astrobotic delivers payload telecommands and telemetry without modification. This system means the customer does not need to consider the different mediums and channels traversed by their data packets.

All payload telecommands and telemetry are securely addressed, and the AMCC and lander verify each packet's meta-data for compliance, ensuring safe transmissions. Customer data is not opened or reformatted allowing for payloads to implement encryption or other data security techniques.

Each payload customer is required to provide an on-site representative at the AMCC during mission operations for rapid response to off-nominal situations. This requirement may be waived for static passive payload types.



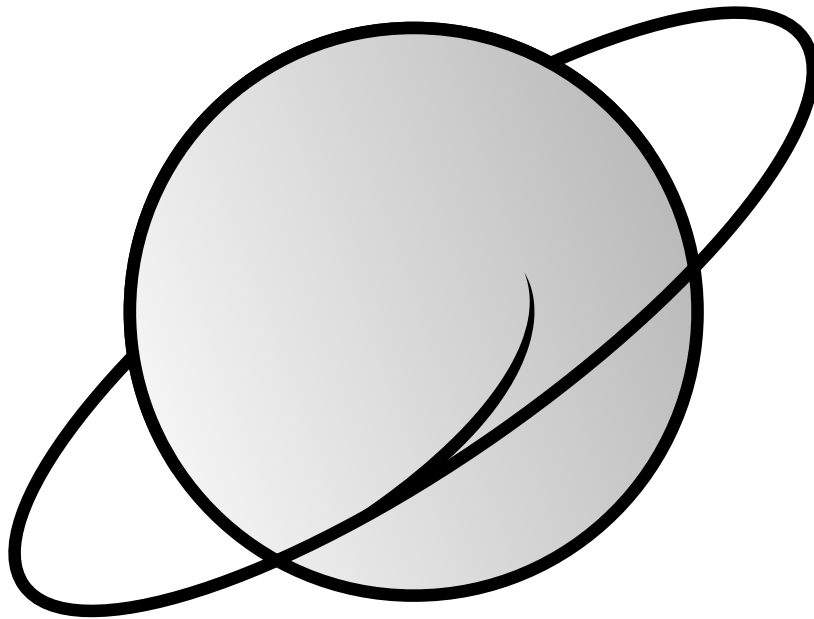

# MISSION OPERATIONS

# LANDING SITE

## PRECISION LANDING

Each Peregrine mission targets a landing ellipse in a region of interest based on the mission and payload requirements. Starting with Mission 2, Peregrine will utilize Astrobotic's Optical Precision Autonomous Landing (OPAL) Sensor to dramatically improve the landing accuracy from a 24 km x 6 km ellipse to a 100 m x 100 m ellipse. Since GPS is not available at the Moon and other planets, the OPAL Sensor uses on-board cameras and computer vision algorithms to detect features on the lunar surface and match these features to onboard maps to provide position updates during landing. Robust, high-speed image processing allows Peregrine to accurately determine its pose as it descends towards the surface.

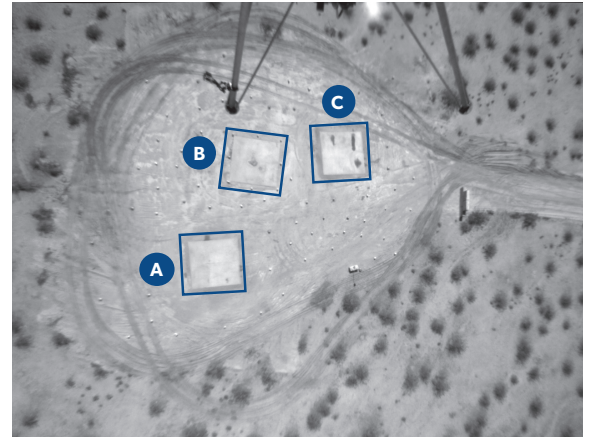
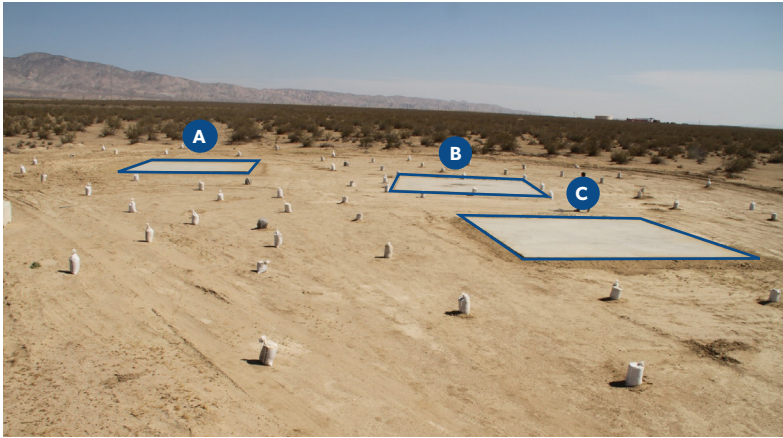

Early version of the OPAL sensor autonomously selects a hazard-free landing site for the Masten Space Systems Xombie Rocket.

## EFFECTIVE SLOPES

Potential landing sites are analyzed based on a wide array of variables; one of the most important being effective slope. The effective slope takes into account natural slopes in the topography and the presence of rocks. Sites are typically selected with an effective slope  $\leq 10^\circ$ . Sites with a maximum expected rock height of 0.3 m are preferred. Improvements to the lander system such as the terrain relative navigation system will enable Astrobotic to select many more landing sites that meet these criteria.

## LOCAL LANDING TIME

Once a landing site has been selected, Astrobotic plans a mission to maximize payload operation time on the lunar surface. For Mission One, Peregrine will land 55-110 hours after sunrise. A lunar day, from local sunrise to sunset on the Moon, is equivalent to 354 hours, or approximately 14 Earth days. At mid-latitudes, Peregrine nominally operates for 192 hours, or 8 Earth days, following landing. Some polar missions may take advantage of unique lighting conditions to operate for longer than a single lunar day.

# MISSION PROFILE

The Peregrine mission profile encompasses five distinct phases, beginning with payload integration to the lander and concluding at the end of the mission.

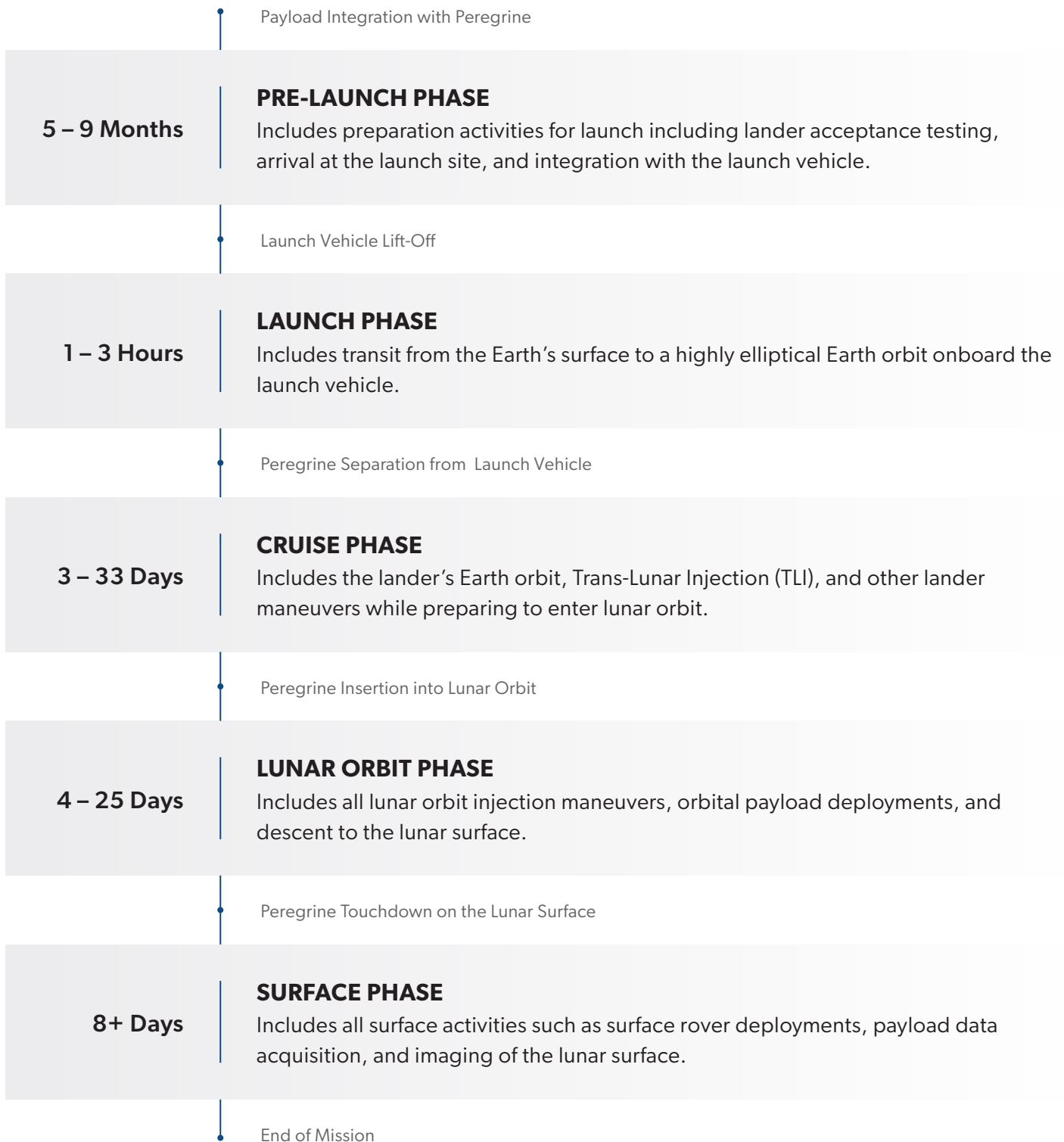



# TRAJECTORY

Astrobotic selects a specific trajectory for every mission based on launch profile and landing site. A generic trajectory, typical for Peregrine missions, is shown below.

- 1 Launch to High Elliptical Orbit Aboard the Launch Vehicle
- 2 Separation from the Launch Vehicle
- 3 Perigee Raise Maneuver
- 4 TLI Maneuver
- 5 Cruise Through Cislunar Space
- 6 Lunar Orbit Insertion (LOI) Maneuver
- 7 Lunar Orbit Hold
- 8 Autonomous Descent Operations
- 9 Landing on the Lunar Surface

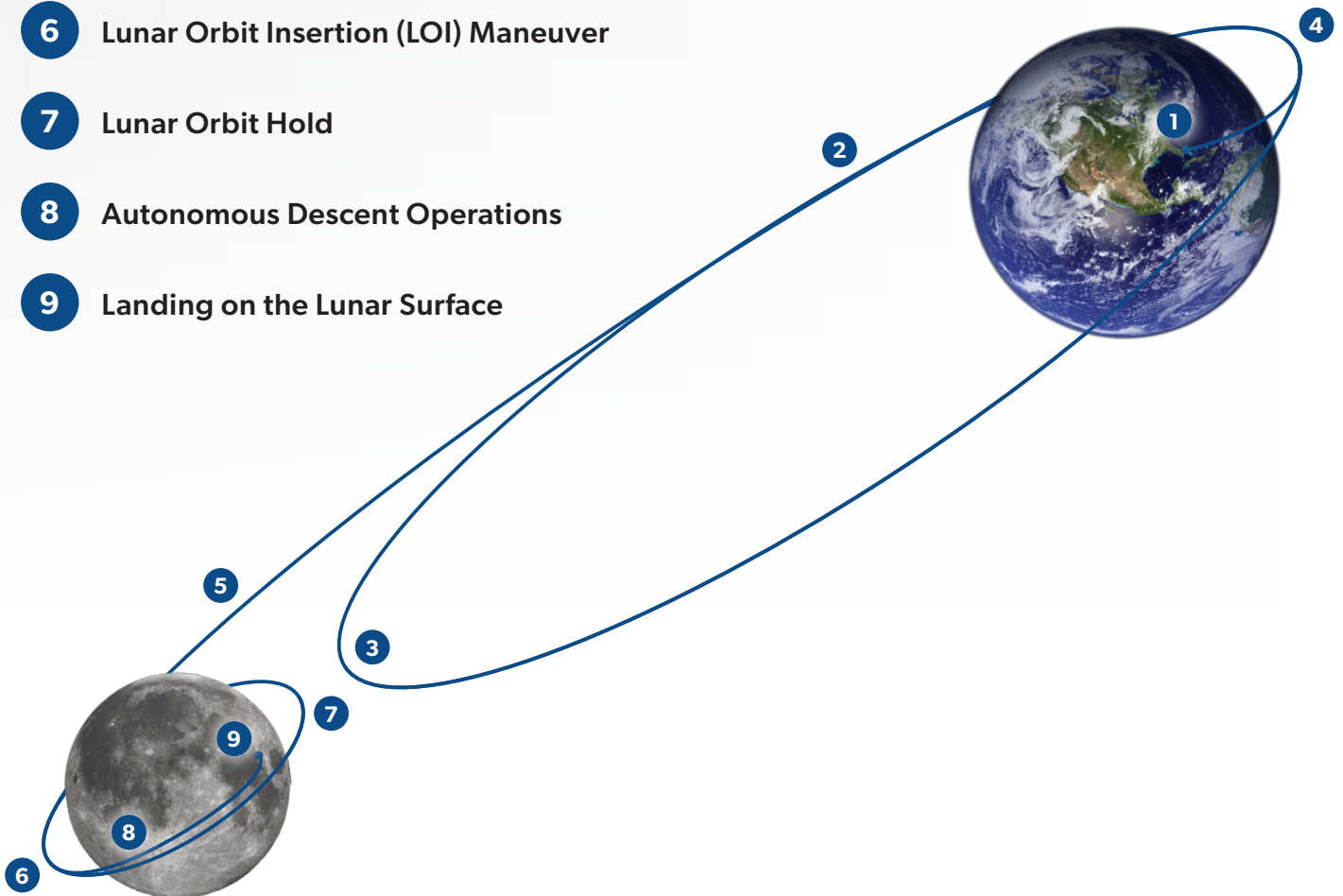

# DESCENT PROFILE

Descent operations take Peregrine from lunar orbit safely to the surface. This phase of flight is completed autonomously by the lander.

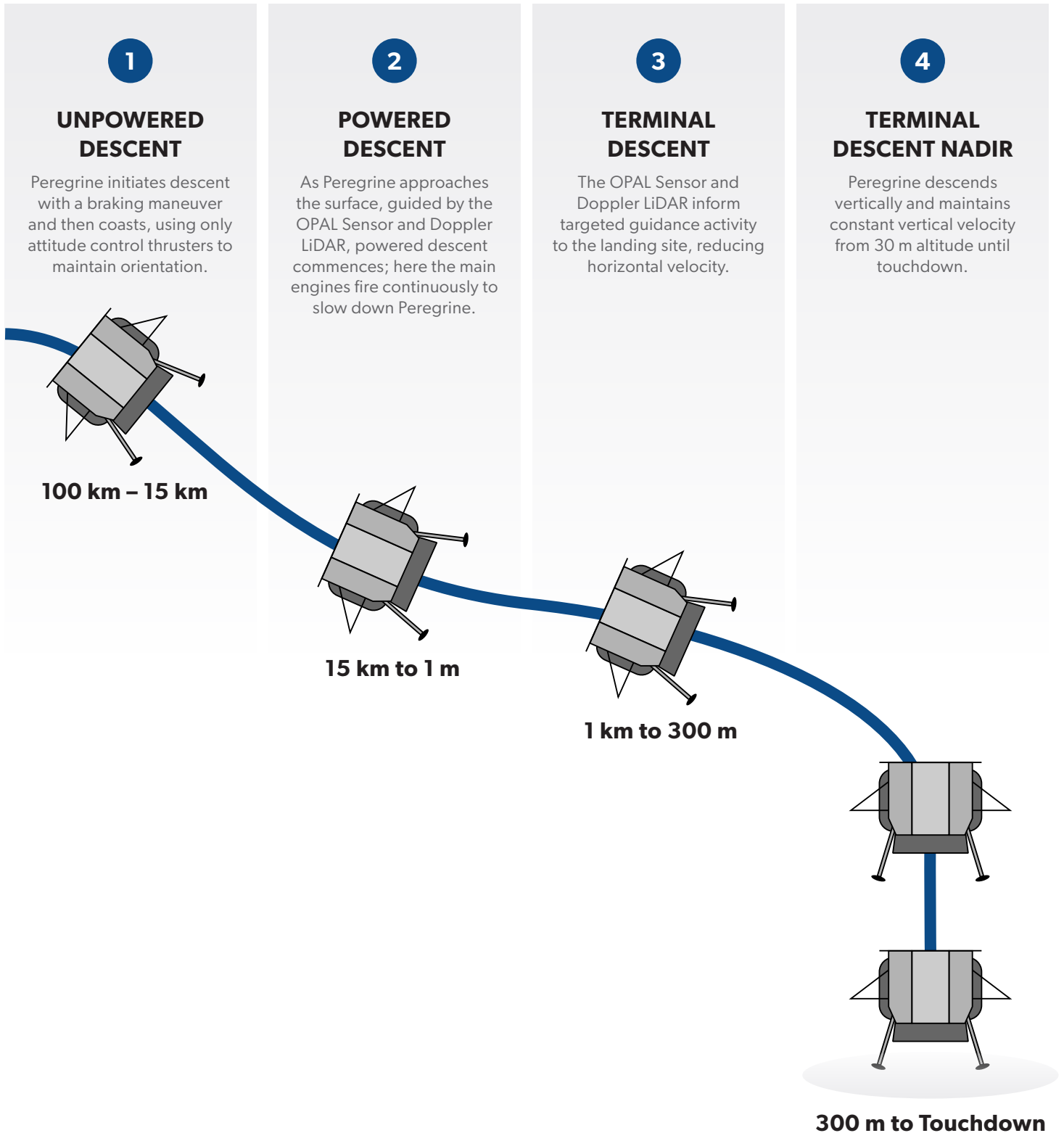

# POWER SERVICES

Peregrine allocates power services based on payload mass, with several modes available to fit the payload concept of operations. Additional power services are available for purchase; please contact Astrobotic for more details. Peregrine defines the following service modes for payloads.

**OFF** No power is provided to payloads.

**NOMINAL** 1.0 W per kilogram of payload.

**PEAK** 2.5 W per kilogram of payload as scheduled by Astrobotic.

**RELEASE** 30 W peak payload power for approximately 60 seconds.

Power service modes provided to payloads change by mission phase as described below.

|         | PRE-LAUNCH   | LAUNCH       | CRUISE                           | LUNAR ORBIT                                   | SURFACE                   |
|---------|--------------|--------------|----------------------------------|---|---------------------------|
| OFF     | As Scheduled | Entire Phase | < 20 minutes per lander maneuver | < 20 Minutes per Lander Maneuver <sup>1</sup> | N/A                       |
| NOMINAL | As Scheduled | N/A          | Default State                    | Default State                                 | Default State             |
| PEAK    | As Scheduled | N/A          | N/A                              | N/A   | As Scheduled              |
| RELEASE | As Scheduled | N/A          | N/A                              | As Scheduled <sup>2</sup>                     | As Scheduled <sup>3</sup> |

<sup>1</sup> Powered descent lasts two hours and is the only lander maneuver to last more than 20 minutes.

<sup>2</sup> Only payloads delivered to lunar orbit are provided release power services in lunar orbit.

<sup>3</sup> Only payloads with deployable or actuated elements on the lunar surface are provided release power services on the surface.

Power services are provided through the SEC. Therefore, power services are available only while the payload is attached to the lander. Deployable payloads take full control of their own power generation and consumption following release from the lander.



# DATA SERVICES

Data services also feature a base allocation by payload mass, with a nominal data rate mode on the lunar surface and a limited data-rate heartbeat mode while in transit. Additional data services are available for purchase; please contact Astrobotic for more details. Peregrine defines the following service modes for payloads. The lander typically cycles between modes as it switches between ground stations.

**OFF** No data services are provided to payloads.

**HEARTBEAT** 10 bps per payload.

**RELEASE** 10 kbps per kilogram of payload.

Data service modes provided to payloads change by mission phase as described below.

|           | PRE-LAUNCH   | LAUNCH       | CRUISE            | LUNAR ORBIT       | SURFACE           |
|-----------|--------------|--------------|-------------------|-------------------|-------------------|
| OFF       | As Scheduled | Entire Phase | 4 Hours per Cycle | 4 Hours per Cycle | 1 Hour per Cycle  |
| HEARTBEAT | As Scheduled | N/A          | 4 Hours per Cycle | 4 Hours per Cycle | N/A               |
| NOMINAL   | As Scheduled | N/A          | N/A               | N/A               | 7 Hours per Cycle |

Unlike power services, data services are dependent on lander contact with ground stations. For payloads Peregrine typically provides data services over an 8 hour cycle. Part of that cycle is spent in LOS and the rest is in AOS depending on ground station availability.

Wired services are provided through the SEC. Therefore, wired data services are available only while the payload is attached to the lander. Wireless data services are available to surface deployable payloads following separation from the lander. Orbit deployable payloads must establish an independent communication connection with Earth following separation from the lander.



# EGRESS PROCEDURES

Each deployable payload is given a time window to perform deployment and any payload-specific preparations. Astrobotic informs the payload customer once their egress window is open. The following compliant safe, arm, and fire techniques must be implemented in the payload design.

## SAFE

The payload deployment mechanism is disconnected from the power (release) signal circuit inside the payload, and the circuit is unpowered.

## ARM

The payload deployment is armed by means of a specific customer command to ready the payload for deployment and internally distribute power services to the release mechanism.

## FIRE

The power (release) signal serves as the fire command. Upon customer request, Astrobotic provides the defined power signal to the Standard Electrical Connector (SEC) interface.

Peregrine maintains power authority over attached payloads and can, by the removal of nominal power services, render payload release mechanism devices inert.

**A sample egress procedure guideline is provided below.**

- 1** The payload charges its batteries with power provided by Peregrine. The payload customer performs any necessary system diagnostic checks and firmware or software updates to prepare the payload for deployment.
- 2** Astrobotic and the payload customer enable restricted payload functionality, allowing the use of internal power systems and onboard radios. A diagnostic check may be performed by the payload customer to verify internal power sources and wireless communication.
- 3** Upon request of the payload customer, Astrobotic commands Peregrine to send the power (release) signal to the payload. Peregrine-provided power and wired communication are discontinued to the SEC.
- 4** Astrobotic and the payload customer confirm successful separation of the payload from the lander.

*NOTE: For orbit deployable payloads, Astrobotic may interface directly with the release mechanism and apply the arm and fire signals with customer confirmation of payload readiness. If desired, this also allows the payload to deploy in an unpowered state until separation from the lander.*



## Astrobotic provides the following forms of confirmation of payload separation.

- 1 Confirmation of provision of the power (release) signal to the SEC interface.
- 2 Visual confirmation of payload separation using the lander status cameras.

Following deployment, all payloads are responsible for their own power management. Orbit deployable payloads also need to ensure separate communications with Earth. Please contact Astrobotic for recommendations on an independent power and communications concept of operations for payloads.

### LUNAR ORBIT EGRESS

Lunar orbit deployments introduce distinct complexities that require additional precautions to be enacted. Payloads are deployed in either the velocity or anti-velocity direction; this results in orbital dynamics that appear to loop back relative to the lander orbit. Astrobotic requires that these loop backs occur outside of a 1 km radius keep-out zone. To be compliant, payloads must provide at least 0.04 m/s velocity relative to the lander upon separation.

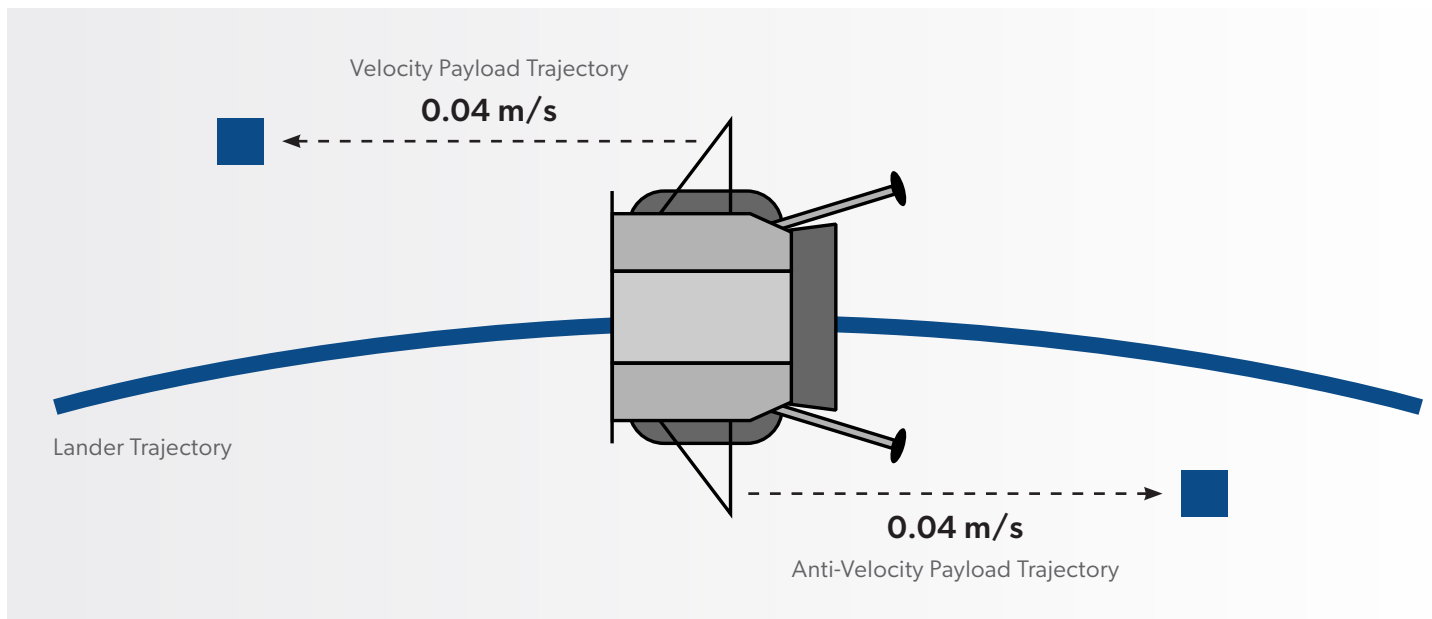

Peregrine nominally holds in several different lunar orbits during the Lunar Orbit phase; not all lunar orbits are available for orbital payload deployment as some may be less stable than others. Astrobotic identifies the available and preferred lunar orbits for payload customer orbital deployments for each mission. To ensure safe lunar orbit operations for all payloads, orbital deployments may occur at slightly varied altitudes for each payload.

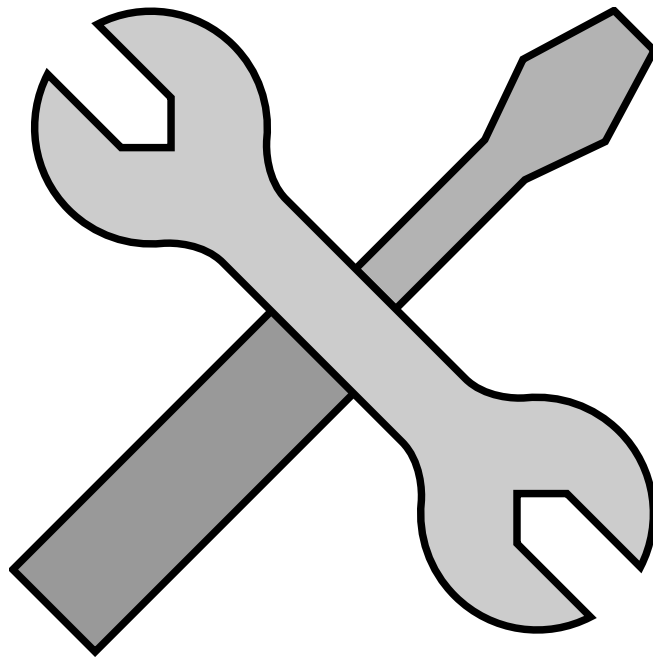

# PAYLOAD INTEGRATION

# MISSION TIMELINE

The diagram below provides a high-level overview of the mission timeline. Astrobotic works with the customer to appropriately tailor this timeline to develop a payload-specific schedule based on payload type and complexity.

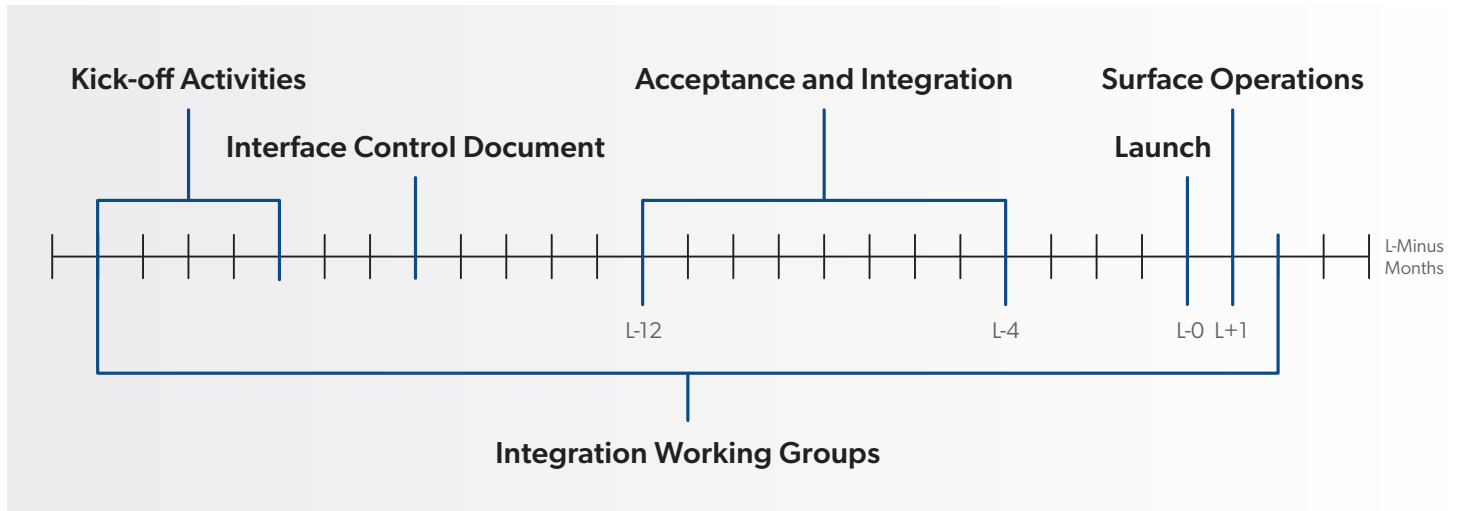

Following contract signature, Astrobotic begins hosting regular Integration Working Group meetings with each payload customer. These meetings, led by an Astrobotic Payload Manager, are the primary forum for technical and programmatic interchanges between the payload team and Astrobotic engineers. Topics for these meetings change as the mission gets closer to launch. Integration Working Group meetings continue until the end of mission.

During the kick-off Activities phase, Astrobotic works to familiarize the payload customer with the lander interfaces and concept of operations. Astrobotic maintains a comprehensive library of payload documentation to aid in this process. The Interface Definition Document (IDD) explains the standard payload interfaces and environments. The Payload Integration Plan (PIP) describes the deliverables and analyses performed by the customer and Astrobotic teams. Astrobotic then works with payload customers to develop an Interface Control Document (ICD), which defines the interface between the payload and the lander.

Payload milestone reviews such as the System Requirements Review, Preliminary Design Review, and Critical Design Review are scheduled by the payload teams and supported by Astrobotic engineers acting as reviewers. The only design review led by Astrobotic is the Payload Acceptance Review.





# INTEGRATION

## PAYLOAD ACCEPTANCE REVIEW

The Payload Acceptance Review (PAR) determines whether the payload is fit for integration with Peregrine. The PAR is nominally scheduled no later than 9 months prior to launch. Additional flexibility can be afforded to less complex payloads utilizing fully standard interfaces and services. The PAR nominally takes place at the Astrobotic integration facility located at the company headquarters in Pittsburgh, PA and is led by the Astrobotic payload management team.

The customer delivers the fully-assembled flight-configuration payload to Astrobotic. To be considered safe to integrate with Peregrine, the payload must complete all verification and validation activities without failures. The final agenda for the review is tailored to the specific payload type and complexity.

## PAYLOAD INTEGRATION

Following a successful Payload Acceptance Review, Astrobotic Integrates the payload with Peregrine. Integration is nominally scheduled between 9 and 5 months prior to launch. Additional flexibility can be afforded to less complex payloads utilizing fully standard interfaces and services. The integration schedule developed by Astrobotic also takes overall accessibility requirements for integration and testing into account.

Integration nominally takes place at the Astrobotic integration facility located at the company headquarters in Pittsburgh, PA and is led by the Astrobotic payload management team.

Astrobotic integrates the accepted payload with Peregrine. The integration specialists follow the payload-specific guidelines for integration provided by each payload customer in a Payload Operations Plan. Additional verification and validation activities are undertaken to confirm a successful integration between payload and lander. The final agenda is tailored to the specific payload type and complexity.

The Payload Integration Plan provides further details on the Integration schedule and procedures. Please contact Astrobotic for the latest version of this document.

## INTEGRATED LANDER TESTING

The fully integrated lander system is functionally tested, and several environmental tests such as thermal and vibration are performed. Once the fully integrated lander is certified, the lander is delivered to the launch site where payloads may perform final functional tests and the lander is integrated with the launch vehicle.

*NOTE: The customer may request or require additional time between the PAR and Integration. Astrobotic reserves the right to repeat aspects of the PAR to ensure any changes to the payload in that time did not impact Astrobotic's ability to accept the payload for integration.*



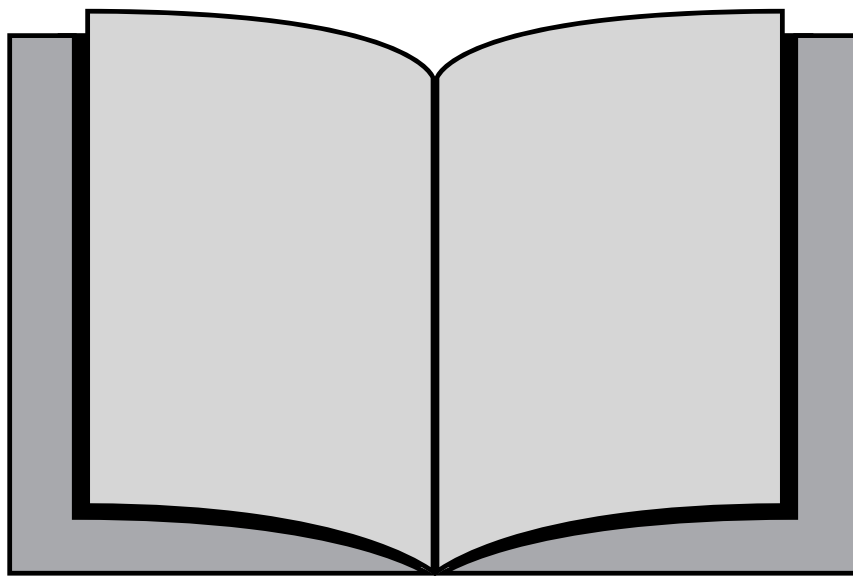

# GLOSSARY

# GLOSSARY OF UNITS

| UNIT   | SIGNIFICANCE  |
|--------|---|
| bps    | bits per second [data rate]   |
| dB     | decibel [sound pressure level referenced to $20 \times 10^{-6}$ Pa] |
| °      | degree [angle, latitude, longitude]                                 |
| °C     | degree Celsius [temperature]  |
| g's    | Earth gravitational acceleration [9.81 m/s <sup>2</sup> ]           |
| Hz     | Hertz [frequency]   |
| kg     | kilogram [mass]   |
| kPa    | Kilopascal [pressure]   |
| m      | meter [length]  |
| N      | Newton [force]  |
| %      | percent [part of whole]   |
| rad    | rad [absorbed radiation dose]                                       |
| s      | second [time]   |
| \$     | United States dollars [currency]                                    |
| V (dc) | Volt (direct current) [voltage]                                     |
| W      | Watt [power]  |



# GLOSSARY OF TERMS

| <b>TERM</b> | <b>SIGNIFICANCE</b>                         |
|-------------|---|
| AMCC        | Astrobotic Mission Control Center           |
| APR         | Astrobotic Payload Requirement              |
| EMI         | Electro-Magnetic Interference               |
| FPGA        | Field Programmable Gate Array               |
| GNC         | Guidance, Navigation, and Control           |
| IAU         | Integrated Avionics Unit                    |
| IWG         | Integration Working Groups                  |
| LOI         | Lunar Orbit Insertion                       |
| M1          | Mission One                                 |
| M2          | Mission Two                                 |
| MMH         | MonoMethylHydrazine                         |
| MON-25      | Mixed Oxides of Nitrogen - 25% nitric oxide |
| PMCC        | Payload Mission Control Center              |
| SEC         | Standard Electrical Connector               |
| SEU         | Single Event Upset                          |
| UDP/IP      | User Datagram Protocol / Internet Protocol  |
| TLI         | Trans-Lunar Injection                       |
| VPN         | Virtual Private Network                     |



# GLOSSARY OF DOCUMENTATION

## DOCUMENT SIGNIFICANCE

|     |  |
|-----|--|
| ICD | <b>Interface Control Document</b><br>The document defines the final lander-payload interfaces and is signed by Astrobotic and the customer; the IDD is used as a template for this document. |
| IDD | <b>Interface Definition Document</b><br>The document defines the standard lander-payload interfaces.   |
| PIP | <b>Payload Integration Plan</b><br>The document details the Payload Acceptance Review and Integration schedules as well as verification and validation procedures.                           |
| POP | <b>Payload Operations Plan</b><br>The document details the appropriate handling of the payload system; it is produced in part by the payload customer and guides Astrobotic operations.      |
| PSA | <b>Payload Services Agreement</b><br>The document serves as the initial contract between Astrobotic and the payload customer; it defines programmatic expectations.                          |
| PUG | <b>Payload User's Guide</b><br>The document provides a high-level overview of the vehicle, mission, as well as the interfaces and services provided to payloads. ( <i>this document</i> )    |
| SOW | <b>Statement of Work</b><br>The document outlines the responsibilities of Astrobotic and the payload customer; it is part of the PSA.  |



# GLOSSARY OF MILESTONES

## DOCUMENT SIGNIFICANCE

|     |   |
|-----|---|
| CDR | <b>Critical Design Review</b><br>The review focuses on the final design of the lander/payload and determines readiness to proceed with fabrication and testing.                       |
| FRR | <b>Flight Readiness Review</b><br>The review focuses on the integrated launch vehicle and determines readiness to proceed with launch operations.                                     |
| LRR | <b>Launch Readiness Review</b><br>The review focuses on the integrated launch vehicle and determines readiness to fuel the vehicle and proceed with launch operations.                |
| ORR | <b>Operational Readiness Review</b><br>The review focuses on the ground segment and determines end-to-end mission operations readiness.   |
| PAR | <b>Payload Acceptance Review</b><br>The review focuses on the flight-model payload and determines readiness to integrate with the lander.   |
| PDR | <b>Preliminary Design Review</b><br>The review focuses on the preliminary design of the lander/payload and determines a feasible design solution to meet mission requirements exists. |
| SIR | <b>System Integration Review</b><br>The review focuses on the flight lander/payload systems and determines readiness to proceed with assembly and testing.                            |
| TRR | <b>Test Readiness Review</b><br>The review focuses on the integrated lander and determines readiness to proceed with testing.   |



# CONTACT US

---

Astrobotic provides several points of contact to address the varied needs of payload customers.

## **BUSINESS DEVELOPMENT**

Our Business Development team is available to current and potential customers for questions on the products and services we provide.

## **CUSTOMER RELATIONS**

Our Customer Relations team is available to signed customers for general programmatic inquiries.

## **PAYLOAD MANAGEMENT**

Our Payload Management team is available to signed customers for any mission-specific or technical needs.

To begin your payload journey, please contact us and we will be happy to direct you to the appropriate Astrobotic team member.

*Email us at:*

**[PAYLOAD@ASTROBOTIC.COM](mailto:PAYLOAD@ASTROBOTIC.COM)**

*We can also be reached using the following contact information:*

**1016 N. Lincoln Avenue  
Pittsburgh, PA 15233**

**412-682-3282**

**[www.astrobotic.com](http://www.astrobotic.com)**

**[contact@astrobotic.com](mailto:contact@astrobotic.com)**



# QUESTIONNAIRE

**For a more personalized experience, please include your specific payload needs when you contact us.**

---

Payload Name

---

Payload Point of Contact: Name, Email/Phone

---

Payload Mission Objectives

---

Payload Preferred Launch Date

---

Payload Delivery Location: Lunar Destination [Orbit/Surface], Additional Parameters (e.g., orbital altitude, orbital inclination, surface region, proximity to a lunar surface feature)

---

Payload Mass

---

Payload Dimensions: Length x Width x Height, Description of Shape

---

Payload Power Needs: Nominal Power [Yes/No], Power (Release) Signal [Yes/No], Additional Needs

---

Payload Communications Needs: Wired Communication [Yes/No], Wireless Communication [Yes/No], Nominal Surface Bandwidth [Yes/No], Heartbeat Bandwidth [Yes/No], Additional Needs

---

Payload Concept of Operations

---

Additional Requirements

*NOTE: You can also share your payload mission details with us through our website:*

***Configure Your Mission***